

PC2000

DC-DC Converter



PC2000-series 1000 to 2000W

Input / Output

- Optimized inputs from 20 to 300 Vd.c.
- Single outputs from 24 to 48 Vd.c.
- Inrush current limit.
- Reverse input voltage protection.

Operation

- High efficiency >89%.
- Operating temperature range -25 to +55°C.
- Convection cooled 1000W.
- Fan cooled up to 1400 to 2000W.

Features

- Alarm circuit with relay output.
- External voltage sense.
- Current sharing.
- Inhibit / Power down input.
- Over voltage protection OVP.
- Output voltage adjustable on frontpanel

EMC

- EN61000-6-2, Immunity.
- EN61000-6-3, Emission.
- EN/IEC61000-4-3, 20V/m
- EN/IEC61000-4-4, 4kV.
- EN/IEC61000-4-5 level 2&3.
- EN50121-3-2

Input and output ratings

Nominal inputs	Input range	Stop level	Code
24 Vd.c.	20 to 32V	<16.8Vd.c.	24
48 Vd.c.	43 to 60V	<33.6Vd.c.	48
110, 127 Vd.c.	93 to 150V	<77Vd.c.	110
220, 250 Vd.c.	187 to 300V	<154Vd.c.	220

Other input ranges can be made on demand.

Input range, is the range we guarantee full output performance, Uout +10%, Iout +5%.

The converter works down to the stop levels.

The output voltage might decrease to approx -10% of nominal output at the stop level.

Voltage	Output	
	Current	Power
24V	42 - 58A	1000 - 1400W
28V	36 - 50A	1000 - 1400W
36V*	28 - 56A	1000 - 2000W
48V	21 - 42A	1000 - 2000W

* NRE might be charged

Output ratings and type code

Output			Input				Cooling
Voltage	Current	Power	20 - 32V	43 - 60V	93 - 150V	187 - 300V	
24V	42A	1000W	PC1000 24/24	PC1000 48/24	PC1000 110/24	PC1000 220/24	Convection
24V	58A	1400W		PC1400 48/24	PC1400 110/24	PC1400 220/24	Fan
28V	36A	1000W	PC1000 24/28	PC1000 48/28	PC1000 110/28	PC1000 220/28	Convection
28V	50A	1400W		PC1400 48/28	PC1400 110/28	PC1400 220/28	Fan
36V	28A*	1000W	PC1000 24/36	PC1000 48/36	PC1000 110/36	PC1000 220/36	Convection
36V	56A*	2000W		PC2000 48/36	PC2000 110/36	PC2000 220/36	Fan
48V	21A	1000W	PC1000 24/48	PC1000 48/48	PC1000 110/48	PC1000 220/48	Convection
48V	42A	2000W		PC2000 48/48	PC2000 110/48	PC2000 220/48	Fan

* NRE might be charged

How to read our product code:

Example **PC1000 24/48**

PC1000 = Family code and power rating

24 = input voltage code 24

48 = Output voltage 48V

Features

- **Current Sharing**
Current sharing is used to balance the load between up to 10 units working in parallel.
- **External output voltage sense**
External sense is used when the voltage regulation at the load is critical.
See output data page 3
The sense can compensate voltage drops up to 5% of the nominal voltage.
- **Alarm circuit**
The alarm relay switches to “ALARM” state if:
 - * The output voltage is not within -10 to +15% of nominal output voltage.
 - * The converter is overheated.
- **Over voltage protection OVP**
A second regulation circuit takes over in case the main regulation fails. The output voltage is limited to approximately +15% over nominal output voltage.
- **Inhibit input / Power down**
The converter will shutdown if the inhibit input is short-circuited by a relay or electrical switch. The current through the short-circuit is 20mA.
Note that there is no electrical isolation between the inhibit and the output.
- **Inrush current limit and Reverse voltage protection**
All models have an inrush current limit circuit. In case the input is connected in reverse voltage the converter will not start. The reverse voltage do not damage the input of the converter.
- **Electrical Safety Installation Class**
The PC2000 series can be installed in different networks, see page 4.

Optional Features

- **Series diode on output**
Specify series diode output when the output is connected in parallel with other power supply to achieve redundancy.
The output is derated 10% on 24V and 5% on 48V.
- **Conformally coating; tropical version**
For use in weather protected area with high ambient humidity or large temperature gradients producing condensation.
- **Train input**
Input voltage range according to train standard EN50155 and IEC60571. See T-input below.

T-input ranges for Mobile applications

Code	Continous range	Uin 0.1s- S2
24T	16.8 - 30Vd.c.	14.4 - 33.6Vd.c.
36T	25.2 - 45Vd.c.	21.6 - 50.4Vd.c.
48T	33.6 - 60Vd.c.	28.8 - 67.2Vd.c.
72T	50.4 - 90Vd.c.	43.2 - 100.8Vd.c.
110T	77 - 137.5Vd.c.	66 - 154Vd.c.

The total output power can be derated on a T-range compared to the output rating table, page 2.

Input voltage range according to train standard EN50155:2001 and IEC60571:1998.

General data / input data

Design topology	Push-Pull
Switching frequency	60 kHz
Emission / immunity	See page 4
Safety EN/IEC60950-1:2001	See page 4
Max. accepted input ripple ¹	
50-400Hz	2% of nominal voltage
Input power at no load	
Input code 24	<8 W
Input code 48, 110,	<17 W
Input code 220	<21 W
Reverse input voltage protection	In start up sequence ²
Inrush current limit	Yes <10xI _{nom}
Dimensions (D x W x H)	285x420x87mm
Weight	8.5 kg

1. Higher ripple affects the input, contact factory.
2. The converter do not start at reverce voltage.

Output data

Source regulation	0.1%
Load regulation (0-100% load)	0.2%
with sense connected	
Load regulation (0-100% load)	0.5%
Transient recovery time for 10%-90% load step to within 3% of nominal output voltage.	<3ms
Output ripple (120kHz) ³	Typ. 30mV p-p
Input ripple attenuation to output (50 to 400 Hz).	150:1
Emission / Immunity	See page 4
Temperature coefficient	0.02% /°C
Min output adjustment range adjustable with a 15 turn potentiometer	
Current limit, rectangular.	105%
Remote sense	Yes
Soft start	Yes
Alarm relay rating (a.c. & d.c.)	30V 300mA
Start-up time	<3s
Hold-up time, contact factory	2-25ms
Efficiency ⁴	89-93%
Operating temperature range at 100% load. (Convection cooling.)	-25 to +55°C
with derating ⁵	-25 to +70°C
Storage temperature range	-40 to +85°C

3. Output ripple might increase to 0.5% RMS of V_{out}, when EN/IEC61000-4-3, 20V/m test is applied
4. Lowest efficiency measured within the whole input voltage range at 100% load.
5. Contact factory for derating as it depends on model. The alarm relay can not be used at +70°C.

Mechanical drawing

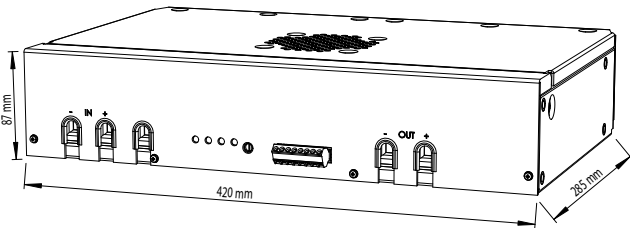

Figure 1. Dimensions and front panel for 24, 48 input

Weight: 8.5 kg

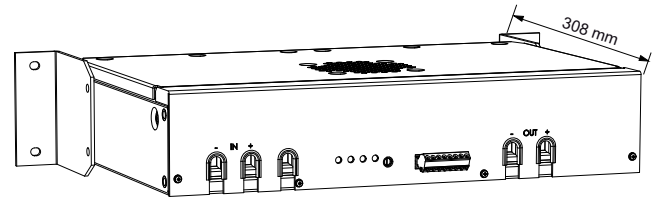
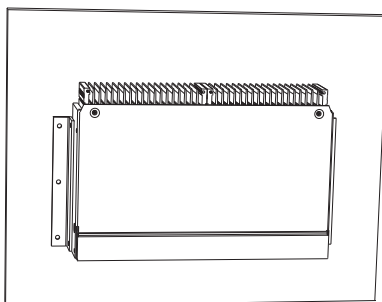

Figure 2. Wall mounting L100-1 and front panel for inputs



PC2000 wall mounted. Using mounting brackets L220-1 (Optional). Only for fan cooled types.

Figure 3. Wall mounting.

3x Single unit PC2000 mounted as one 2U 19" unit using standard brackets L89-3.

3x Single unit PC2000 mounted backwards as one 2U 19" unit using standard brackets L89-3.

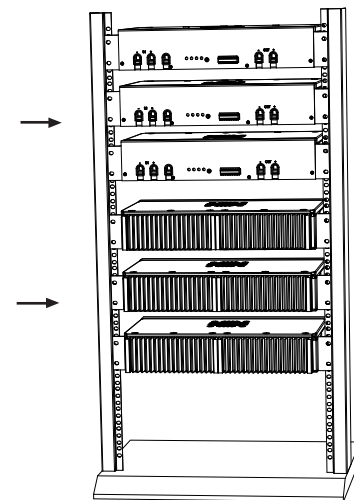

Figure 4. 19''-rack moun-

PC2000 meets the requirements defined by CE mark as an apparatus.

PC2000 meets requirements of EMC directive and low voltage directive (LVD).

Thus a PC2000 can be used as free standing unit or in installations as well as systems designed according to "The modular approach". PC2000 can be used in installation without further EMC tests, if our installation instructions are followed.

Please note that product standards can demand different levels or other basic standard tests. We test according to levels below. For higher levels or other tests, please contact factory.

The PC2000 use the safety standard EN/IEC60950-1:2001 for electrical safety. For the EMC it meets the requirements of EN/IEC61204-3, EN50121-2-3:2000, IEC62236-2-3:2003.

and the generic EMC standards: EN/IEC61000-6-2 (Immunity)

Network	Installation class	Input code
Primary circuit max 250Va.c.	class II ⁽¹⁾	110, 220
Primary circuit max 250Va.c.	class I ⁽²⁾	110, 220
Secondary circuit	class I ⁽²⁾	all
SELV circuit	class I ⁽²⁾	24, 48

1. Pollution degree 2.
2. Pollution degree 3.

Isolation testable levels	Test voltage
Input / output: Input code: 24, 48, 72	2.5kVd.c.
Input code: 110, 220	3kVa.c. / 4.3kVd.c.
Input / Alarm Input code: 24, 48, 72	2.5kVd.c.
Input code: 110, 220	3kVa.c. / 4.3kVd.c.
Input / Case Input code: 24, 48, 72	2.5kVd.c.
Input code: 110, 220	3kVa.c. / 4.3kVd.c.
Alarm / Case	2.5kVd.c.
Output / Case on <75Vd.c. output	2.5kVd.c.
Output / Alarm	2.5kVd.c.

EMC

EMC-standards	EMC-performance		Remarks
Emission standars	Input	Output	
EN55011/EN55022 (0.15-30MHz)	Level B	Level B	
EN55011/EN55022 (30-1000MHz)	Level B		Enclosure test
Immunity standards	IEC/EN61000-6-2		
EN/IEC61000-4-2	8 kV/15 kV		Contact / air, Enclosure test
EN/IEC61000-4-3, see note 3	20 V/m AM-Modulated		Output ripple can increase to 0.5% of Vout Enclosure test
EN/IEC61000-4-4	4 kV	4 kV	
EN/IEC61000-4-5, Input code 24, 48, 72	0.5kV / 1 kV	0.5kV / 1 kV	Line-line 2Ω / Line-case 12Ω
EN/IEC61000-4-5, Input code 110 ⁴ , 220 ⁴	1kV / 2 kV	0.5kV / 1 kV	see note 4
EN50155 Figure 4, 1.8kV 1.5/50μs	Yes		Line-line 100 Ω
EN/IEC61000-4-6	10 V _{RMS}	10 V _{RMS}	AM-Modulated
EN/IEC61000-4-8	30 A/m		Enclosure test
EN/IEC61000-4-10	Not sensitive		Enclosure test

3. 10V/m do not show any influence.

4. Higher level 2kV / 4kV with external filters, contact factory.

Contact

For updates on this datasheet we refer to www.polyamp.com
Specifications subject to change without notice.



Polyamp AB Box 229 597 25 Ätvidaberg Sweden
Telephone: +46 120 854 00 Telefax: +46 120 854 05
<http://www.polyamp.se>, <http://www.polyamp.com>
E-mail: info@polyamp.se

Distributor

Schulz-Electronic GmbH
Dr.-Rudolf-Eberle-Straße 2
D-76534 Baden-Baden

Fon +49.7223.9636.0
Fax +49.7223.9636.90

vertrieb@schulz-electronic.de
www.schulz-electronic.de