

CAPACITOR CHARGER FORM

Could you briefly describe your application :

Please fill in the part corresponding to your application (complete or partial discharge) ?

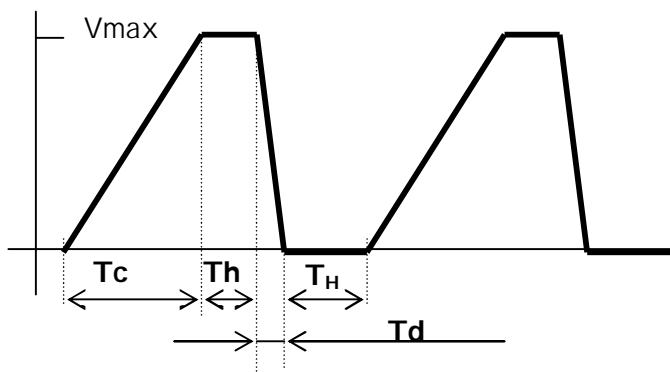

$T = T_c + T_h + T_d + T_H$

Load capacitor:

Maximum Voltage (Vmax):

Time of charging (Tc) :

Time of discharging (Td):

Holding time (Th + TH):

Periodicity (T) :

Load factor* :

Complete discharge

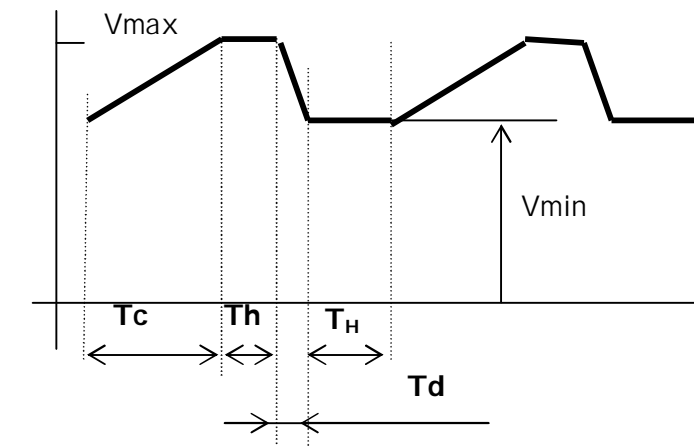

$T = T_c + T_h + T_d + T_H$

Load capacitor :

Maximum Voltage (Vmax) :

Vmin :

Time of charging (Tc) :

Time of discharging (Td) :

Holding time (Th + TH) :

Periodicity (T) :

Load factor*:

Partial discharge

*Load factor: how often is the charger used? example: 5mn each hour or continuously 24h/day

Polarity : Quantities:

Special request :

Your Name :

Your title :

Your Company Name :

Your phone number :

Your fax number :

Your email :