

Höcherl & Hackl GmbH  
Industriestr. 13  
D-94357 Konzell



Tel.: (+49) 9963 943010  
Fax: (+49) 9963 9430184  
eMail: support@hoecherl-hackl.com  
Internet: http://www.hoecherl-hackl.com

**SN:**

**Manual Version: PL(II) 05 07-13D E**

**Höcherl & Hackl GmbH**  
**Electronic Load PL1006 Standard** Rev.1  
**Operating Instructions**



## Contents

<b>1</b>	<b>General Information</b> .....	<b>3</b>
1.1	Electronic Safety .....	3
1.2	Warranty .....	4
1.3	Maintenance and Cleaning .....	5
1.4	Calibration.....	6
1.5	Operating Environment.....	6
1.6	Device Symbols .....	7
1.7	Supplied Accessoires .....	8
<b>2</b>	<b>Technical Data</b> .....	<b>9</b>
<b>3</b>	<b>Operating</b> .....	<b>12</b>
3.1	Control Elements .....	12
3.2	Connections at the Back Panel.....	13
3.3	Power Connection .....	14
3.4	Connection of the Unit under Test .....	14
3.5	System bus interface .....	16
<b>4</b>	<b>Operating Range</b> .....	<b>16</b>
	<b>Operating Modes and Load Settings</b> .....	<b>17</b>
4.1	Operating Mode Current .....	17
4.2	Operating Mode Resistance .....	18
4.3	Dynamic Operating Mode.....	19
4.4	Load Current Setting by Analog Signal .....	20
4.5	Battery Tests .....	21
4.6	Operating Mode Voltage using the Battery Test Function.....	22
4.7	Loading up to Short Circuit.....	22
<b>5</b>	<b>Load on/off</b> .....	<b>23</b>
<b>6</b>	<b>Master/Slave Mode</b> .....	<b>23</b>
<b>7</b>	<b>Analog I/O Port</b> .....	<b>25</b>
7.1	Signals and Functions .....	25
7.2	Allowed Levels:.....	27
7.3	Connector Pin Assignment.....	28
7.4	Analog Control Signals .....	29
7.5	External Load Activation .....	32

---

7.6	Status Signal for Overload.....	32
<b>8</b>	<b>Protection Facilities and Overload Display .....</b>	<b>33</b>
<b>9</b>	<b>Load until Short Circuit.....</b>	<b>35</b>
<b>10</b>	<b>19"- Fitting.....</b>	<b>37</b>
<b>11</b>	<b>Troubleshooting.....</b>	<b>38</b>
11.1	Stability Problems by Fulfilling the Resonance Condition.....	38
11.2	Couplings by Current Lines .....	38
11.3	Distorted Current Rise for Dynamic Operating .....	38
11.4	Measuring the Current Rise Time .....	39
11.5	Distorted Anlaog Measurement Signals .....	39
	<b>Declaration of Conformity .....</b>	<b>40</b>

# 1 General Information

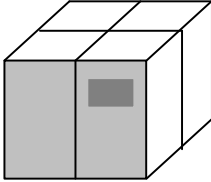

After unpacking the device should be checked for mechanical damages and loose parts inside of the casing.

**If there are damages or loose parts, the device mustn't be operated!**

If the device has been damaged while transportation, please contact the carrier, write a report down on the consignment bill and cause the carrier to sign it.

Please remember, that any complaints later than three days after receiving the goods generally aren't accepted by the carrier.

Please inform immediately the supplier of the device.

## 1.1 Electronic Safety



The device has been manufactured and tested according to DIN EN61010 Part 1 (protection measures for electronic measuring devices and controllers).

According to protection class 1, all touchable parts of the casing are connected to the grounding wire. For the operating of the devices, all protection contact systems have to be established.



**It's inadmissible to remove the protection contact connection for the power cable or inside the device!**



**If the operating could be dangerous, the device has to be de-activated immediately and to be secured against an inadvertant operating.**

This can be the case, if:

- the device shows mechanical damages
- the device contains loose parts
- build-up of smoke
- the device has been overheated
- liquids have poured into the device



**Before opening the device, all voltage sources have to be disconnected.**



**Checkings with open device, repairs or balancings only may be carried out by skilled personal, who is familiar with all security instructions.**



**For devices, that can be operated, while there are touchable dangerous voltages, a touch protection by covering the input terminals or by integration in other casings, racks etc has to be realized.**

## 1.2 Warranty

Before the delivery all devices are tested in an excessive quality controlling as well as in an 8 hours lasting continuous operating under full load. Early failures will be detected, but some components possibly fail later.

Höcherl & Hackl offers a 24 months lasting warranty, under the pre-condition, that the device hasn't been changed and the failure has occurred while correct operating.

Defects will be remedied by repair or replacement, after they are registered and accepted by Höcherl & Hackl or one of the representatives.

Since H&H doesn't know neither the exact application of the electronic loads nor the physical conditions of the units under test no warranty for the correct

operation of a whole system in the customer's sense can be given.

There's no warranty, if the device has been damaged because of exceeding the technical specifications, especially exceeding the maximum allowed input voltages.

The replacement of the overvoltage protection diode as well as defects, that occurred because of wrong poling, never are accepted as warranty cases.

Warranty excludes expendable parts and consumer material as well as fuses, relays, contactors and air filters.

Defects originating from the transportation are also excluded from the warranty.

Location of the warranty fulfillment is 94357 Konzell. It's the client's duty to deliver the faulty device, together with a detailed description of the detected faults, carriage free. Please provide a telephone number and a contact person for queries.

For warranty repairs at the clients location the travelling expenses will be debited.

For the delivery by carrier or packet delivery services, it's recommended to use the original packing. Devices starting from a size of 6HU are to be fastened on a pallet.

We advise against delivery by postal services!

If the original packing is not available, you can order it by Höcherl & Hackl (cost price). Please specify the device type.

**Packages, that are not carriage free, will not be accepted!**

## H&H Service

### **Within the guarantee period:**

H&H guarantee:

- Material and work time are free.
- The repair takes place at H&H.
- Forwarding expenses to H&H are to be paid by the orderer.
- H&H takes over the costs of the back dispatch.

Guarantee locally:

- Material and work time locally are free.
- The costs for travelling, driven km and if necessary overnight accommodation are charged.

### **At expiration of the guarantee period:**

H&H repair:

- Material and work time are charged.
- The repair takes place at H&H.
- Forwarding expenses to H&H and the back dispatch are to be paid by the orderer.

Repair locally:

- Material and work time for the repair are charged.
- The costs for travelling, driven km and if necessary overnight accommodation are charged.

## 1.3 Maintenance and Cleaning



For the maintenance of the devices all cooling paths have to be cleaned regularly – because of the force-ventilation there will be dust on the cooling bars and fans.

This dust can cause, that the device doesn't fulfil its nominal performance, and maybe is shutoff because of overtemperature.

Do the cleaning with compressed air. Deactivate the device and disconnect it from all voltages. Now the top and bottom plate can be removed, to allow access to all positions.

Blow the air also through the back panel at the cooling bars, because there can be a lot of dust.

The cover and the front panel may only be cleaned by a cloth, moistured by pure water. Obstinate dirt may be removed by using glass detergent. When cleaning the cover, make sure that no liquids flow into the device.

## 1.4 Calibration

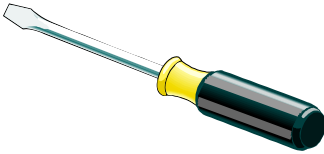

Several important settings of the devices should be checked in regularly time intervals, for example the setting precision and the display accuracy.

The recommended calibration interval amounts to 1 year.

If there are deviations exceeding the specified tolerance, the device should be checked and recalibrated immediately.

You can send the device to Höcherl & Hackl, where it will be checked and recalibrated for a fixed price.

## 1.5 Operating Environment

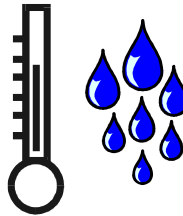

The allowed environment temperature ranges from +5°C to +40°C. For storage and transport the temperature must not exceed a range between -25°C and +65°C. During the storage no condensation and freeze is permitted because of sudden temperature changes. Dewfall is inadmissible.

The maximum operating height of the devices amounts to 2000m over NN.

According DIN EN 61010 the devices support the pollution degree 1 and over voltage category 2.

The allowed humidity comes to 80% upto 31°C, linear decreasing to 50% upto 40°C.

The devices should be operated in clean, dry rooms. They mustn't be operated in environments with very high dust contents in the air, under the danger of explosion or in face of aggressive chemical influences.

The device has to be operated in the specified alignment.

Connection lines for the device mustn't be longer than 3m.

The load lines shall be twisted. If you use sense lines, twist them also.

(But do NOT twist the load lines with the sense lines!)

In IEEE488 operation, a high-quality IEEE488 cable with good shielding shall be used.

Sufficient cooling has to be provided. The air input, i.e. the front panel, as well as the air output, i.e. the back panel, have to be free, to provide a sufficient cooling. The distance between back panel and wall or other things has to be at least 70 cm, to avoid heat build-ups.

When fitting the device into a rack, a free air output has to be guaranteed.



**Never operate the device, while the back door is shut!**



**For back doors with integrated air grid the performance of the device can decrease.**



**For higher environment temperatures a performance derating has to be taken in account (see *Technical Data*).**

## 1.6 Device Symbols

Symbol	Meaning
	Direct Current (DC)
	Alternating Current (AC)
	Direct or Alternating Current
	Three-Phase Alternating Current
	Grounding
	Protective Grounding Wire
	Chassis Ground
	Equipotential Connection
	On (Energy)
	Off (Energy)
	Continuous Double or Increased Isolating Wire
	Warning! Dangerous Electrical Voltage!
	Warning! Danger Area!

## 1.7 Supplied Accessoires

Any PL series load comes with the following accessoires:

- 1 pc. mains supply cable
- 1 pc. operating manual
- 1 pc. quality certificate
- 2 pc. screw M8x25
- 4 pc. washer M8
- 2 pc. snap ring M8
- 2 pc. nut M8

## 2 Technical Data

### Electronic Load Model PL1006 Standard <sup>Rev.1</sup>

#### Limits:

Continuous Power:	1000 W (for $T_A$ upto 21°C)
Short-term Power:	1800 W (Duration and Height are dependent on the temperature of the cooling aggregate.)
Derating:	-1.2%/°C for $T_U > 21°C$
Max. Input Voltage:	60 V
Min. Input Voltage:	1.4 V for full nominal current, linear derating to 0V
Max. Load Current:	100 A
Rise and Fall Time:	75 $\mu$ s (10% ... 90% Inom)

**Operating Modes:** Constant Current, Constant Resistance, I/U Operating

#### Setting Ranges:

Current:	0 ... 100 A
Resistance:	from 0.05 Ohm

#### Setting Accuracy:

Current:	0.4% of Setting, 0.05 % of Current Range
Resistance:	5 % of Setting, 0.5 % of Resistance Range between 5% to 100% of Voltage Range
Long-time Stability:	better 0.2 %
Temperature Coefficient:	200 ppm/°C

**Presetting Function:** Current, with direct display of the setting in A

Accuracy:	0.2% plus Setting Accuracy in the particular operating mode
-----------	---

#### Dynamic Functions:

Two adjustable Load Levels:	0 ... 100 A
Two Activation Times:	0.5 ms ... 500 ms, $\pm 10$ %, $\pm 0.2$ ms

#### Analog Programming:

0 ... 10V for:	Current Setting 0 ... 100 A
0 ... 5V for:	Current Setting 0 ... 100 A

Accuracy:

10V:	0.5% of setting, $\pm 20$ mV
5 V:	1.5% of setting, $\pm 20$ mV

Input Resistance: 20 / 10 k $\Omega$  for 10V / 5 V

Allowed Potential:  $\pm 2$ V of the GND Control Input to negative Load Input

**Measurement Outputs:**

0 ... 10V for      Current: 100 A  
                         Voltage: 60 V  
                         Power: 1800 W  
                         Master: for Master/Slave Connection  
                         Reference: 10.5V  $\pm$ 4%

**Accuracy:**      Current: 0.3 % of setting  $\pm$ 20 mV  
                         Voltage: 0.2 % of setting  $\pm$  20 mV  
                         Power: 5% of setting,  $\pm$ 30mV

**Parallel Operation:** Upto 5 devices in Master/Slave Mode

**Connections:**

Load Input:            FK8  
Sense Input:          SUB-D  
Input Resistance:    > 50k $\Omega$  for deactivated Input

**Cooling:**            Two-phased temperature-controlled fan cooling

**Mains Supply:**     115/230V +/-10% 50..60Hz

**Mains Input Fuse:** at 230V~: 2\* TT 0.4A, 5 x 20mm, 250V~ serial  
                                 at 115V~: 2\* TT 0.4A, 5 x 20mm, 250V~ parallel

**Power Consumption:**      50 VA

**Mechanics:**

Dimensions:          Width: 19''' (444mm)  
                                 Height: 2HU (88.9mm)  
                                 Depth: 390mm

Weight:                12 kg

**Noise:**                59 dBA

**Safety, EMV:**            see CE Declaration

**Security:** Power Limitation

Current Limitation  
Overvoltage Limitation  
Overtemperature Protection  
Transient Protection  
Reverse-Connection Protection up to max. load current

**Potential of the  
inputs terminals:**

the input terminals are isolated against the earth potential.  
It may be shifted with max. 125 V from the earth potential.

**Programming:**

**Setting Functions:**

Current: 12 Bit (Resolution: 100 A / 4096)  
Resistance: 12 Bit (Resolution non-linear, because of the function 1/x)

**Measurement Functions:**

Current: 13 Bit (Resolution = 100 A / 8192)  
Accuracy:  $\pm 0.5\%$ ,  $\pm 10$  LSB, Measurement Rate ca. 100 ms  
Voltage: 13 Bit (Resolution = 60 V / 8192)  
Accuracy:  $\pm 0.2\%$ ,  $\pm 5$  LSB, Measurement Rate ca. 100 ms  
Power: is calculated using voltage and current measurements

**The indicated accuracies refer to an ambient temperature of 25°C +/-5°C.**

### 3 Operating

#### 3.1 Control Elements

The control elements of all devices of the series PL have the same alignment. According to the device type the front panels only differ in their widths.

##### Front Panel

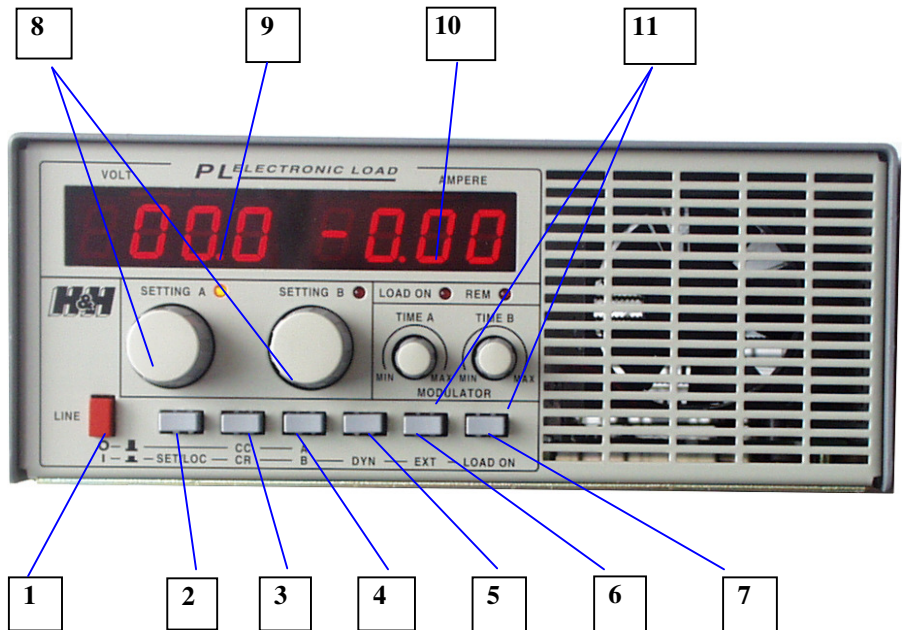

- 1 Power Switch
- 2 Push-button for Load-Presettings
- 3 Switch for Operating Mode R or I
- 4 Alternation Switch for Setting Potentiometer A or B
- 5 Switch for Dynamic Operating
- 6 Switch for Load Setting by External Signal
- 7 Switch for Load on/off
- 8 Setting Potentiometer for Values A and B
- 9 Voltage Display
- 10 Current Display
- 11 Setting Potentiometer for Modulator Times A and B

### 3.2 Connections at the Back Panel

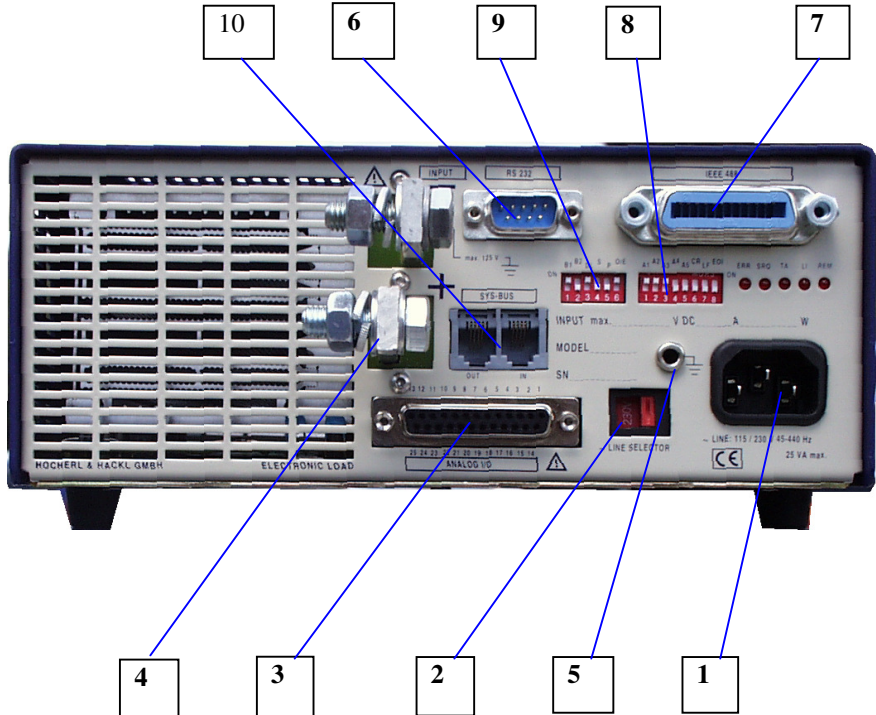

- 1 Power Connection
- 2 Selection Switch for Line Voltage
- 3 Analog I/O Port
- 4 Load Input PL3XX (for PL6XX and PL9XX at the opposite Side)
- 5 Connection for Protective Ground
- 6 RS 232 Port
- 7 IEEE 488 Port
- 8 IEEE 488 Address Switch
- 9 RS 232 Configuration Switch
- 10 System Bus Port

### 3.3 Power Connection

Before connecting the device to the power supply, ensure that the value set at the selection switch for line voltage matches with the power connection.

The selection switch for line voltage can have two positions:

**115 V or 230 V**

The allowed operating range amounts to  $\pm 10\%$  of the line voltage.



Ensure the correct connection of the grounding wire. The device must not be operated if the grounding wire is not connected.

After establishing the connection with the voltage line, the device is activated by pushing the switch labeled "Power". The device is active, when the button is pushed down. Pushing the button again will deactivate the device.

### 3.4 Connection of the Unit under Test

Depending on the device type the unit under test can be connected at the back of the device using touchsafe terminals, or power bars.

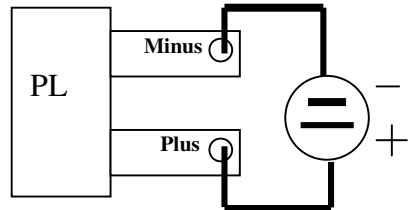

Connection of the Unit under Test

The terminals labeled "Input" are the live inputs. For the devices upto 120V nominal voltage there are additional leading lines (sense) for the voltage measuring.

This leading lines are provided at the Analog I/O Port and have to be lead in separate lines upto the voltage measurement.

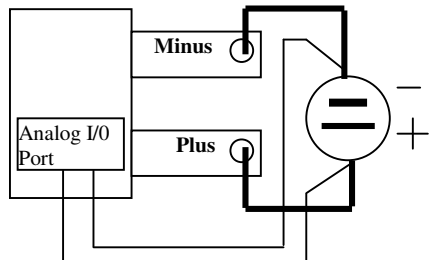

Connecting the Unit under Test with Sense

If there is no connection at the terminals labeled "Sense", the voltage will be

measured automatically at the terminals labeled "Input".

The Sense Lines are provided at the following pins of the Analog I/O Port:

**Sense -:** Pin 13  
**Sense +:** Pin 24

Further information is provided in the chapter about the Analog I/O Port.

**Connection example with two electronic loads and a bipolar input voltage:**

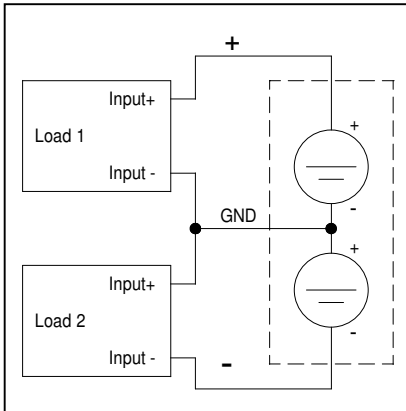

**When connecting the unit under test please obey the following aspects:**

- Before connecting the unit under test the device input labeled "Input" has to be deactivated (the LED LOAD ON must be off!).
- Take care for the right polarity! A wrong poling can damage the device!
- Don't use higher voltages than the maximal allowed input voltage at the terminals. Higher voltages can damage the device!
- Use cables with sufficient cross-section for connections.
- For the operating with touch-dangerous voltages all touchable parts of the input (copper bars, screws, parts of the cables or cable terminals) have to be covered or protected against inadvertently touching by fitting the device in racks or comparable units.
- The cables should not be longer than 2m because of the stability of the current regulation

### 3.5 System bus interface

If the device has got an IEEE488 interface the system bus input may not be connected.

H&H therefore prevents connecting the system bus input in this case.

## 4 Operating Range

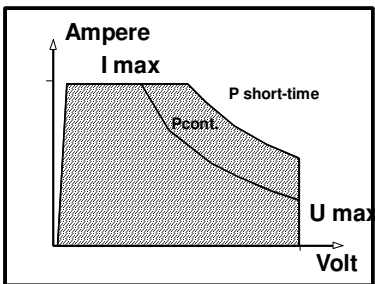

The operating range of the device is determined by the minimum or maximum operating voltage, the maximum current and the maximum power consumption.

#### Voltage:

The minimal operating voltage amounts to about 1.4 V.

Using a decreased load current it's possible to load voltages which are far under this range.

If the input voltage is not sufficient to control the set load, the voltage display will blink.

#### Current:

The maximum settable load current amounts to ca. 102% of the specified nominal current.

If there are set resistance values in the operating mode resistance, that would require higher currents at a corresponding input voltage, the current will be limited and this state will be indicated by a blinking current display.

#### Power:

The device has got two limiting values for the load consumption.

- the nominal load
- the short-term load

The continuous load can be consumed steadily by the device. The short-term load can amount upto 3.3 times as much as the continuous load.

The duration of the short-term load depends on the height of the overload and the temperature of the power unit.

Beginning in a cold status (cooler temperature = 21 °C) 3.3 times of the nominal load can be consumed for about 5 seconds.

If the allowed power limit is exceeded, the voltage display and the current display blink alternately.

When the unit is assembled in a 19" rack

there max. power cannot be taken because of the restricted cooling conditions.

## Operating Modes and Load Settings

The device can be used in the following operating modes:

- **Operating Mode Current C**
- **Operating Mode Resistance R**

The appropriate operating mode is selected using the C-R Switch.

If the button is pushed down, the operating mode R is selected.

If the button is not pushed down, the device operates in the operating mode current C.

The device provides two setting potentiometers, SETTING A and SETTING B.

The potentiometers are equivalent. Depending on the selected operating mode the load current or the load resistance will be set.

Using the Switch A-B the potentiometers are changed.

For the dynamic operating the in-built clock-generator is responsible for this change.

The LEDs beneath the potentiometers show, which potentiometer is the active one.

For dynamic tests the LEDs are blinking in the pulse of the load change.

### 4.1 Operating Mode Current

The set current is independent of the input voltage. A high precise current regulation guarantees that changes of the input voltage won't affect the load current.

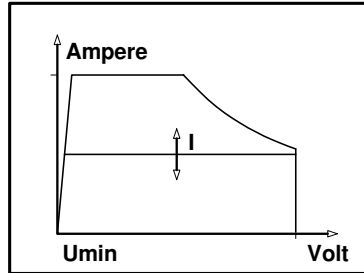

#### Usage:

- Load testing of power supplies
- Measurement of the internal resistance of voltage sources
- Measurement of capacitance of batteries and accumulators

If the input voltage is too low to control the set load, the voltage display will blink.

#### Pre-Setting:

To pre-set the current without a connected unit under test, push the key labeled "SET/LOC".

The amperemeter display shows the current, that will flow after connecting the unit under test.

For tests, where the unit under test mustn't be pre-loaded for setting aspects, for example for the capacity measurement of batteries, the load values can be set using this method.

If the unit under test is already connected and shouldn't be loaded while setting, the load input "LOAD ON" has to be deactivated.

For the presetting the key SET/LOC has to be pushed and the desired set point has to be adjusted using the selected setting potentiometer.

The amperemeter shows the load value, that is put onto the unit under test after activating the input.

## 4.2 Operating Mode Resistance

The current conforms to Ohm's Law and changes linearly with the input voltage.

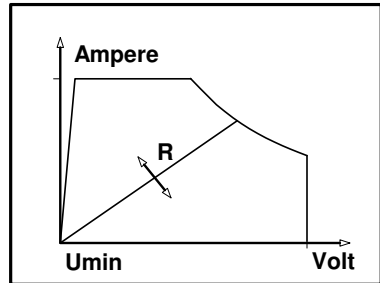

### Usage:

- Replacement of power resistors
- Measurement of the V/C-transition of power supplies

If the input voltage is too low to control the set load, the voltage display will blink.

### Pre-Setting:

To preset the resistance, the load voltage has to be put onto the input.

If the key labeled "Set/Local" is pushed, the amperemeter shows the current, that would flow through the set resistance.

The set resistance is calculated using the input voltage at the current display.

### 4.3 Dynamic Operating Mode

Dynamic loads are supported under the operating modes C and R.

To activate a dynamic load push the button "DYN".

Using the potentiometers for "SETTING A" and "SETTING B" two different load levels are adjustable.

The duty cycles for the load values A and B are determined using the potentiometers "TIME A" und "TIME B".

The setting range amounts to 0.5 ms upto 500 ms.

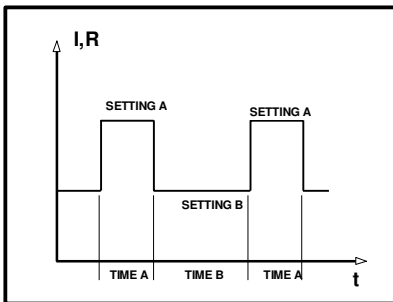

The rise and fall time of the two load levels take place with maximal controlling speed of the device.

#### Controlling dynamic load levels by external pulse:

The load levels can be switched using a signal at the Analog I/O Port: Push the two buttons "EXTERN" and "DYN".

The following pins of the Analog I/O Port are used:

A/B: Pin 2

Pull Up: Pin 14

If nothing is loaded, the setting of the potentiometer for SETTING B is activated.

By setting line A/B to Pull Up, the setting of the potentiometer for SETTING A will be activated.

#### Trigger Output for dynamic load changes:

For triggering external measuring instruments or for an exact time measuring using counters a synchronous trigger signal is provided at the Analog I/O Port.

The following pins of the Analog I/O Port are used:

TRG\_OUT: Pin 15  
GND\_EXT: Pin 1

The line TRG\_OUT provides a signal with 0 ... 5 V.

#### Pre-Setting:

To preset the load current or the load resistance for the dynamic operating mode the dynamic function has to be deactivated. The presetting occurs as described in the sections 5.1 and 5.2. When activating the dynamic function all statically set values are preserved.

#### 4.4 Load Current Setting by Analog Signal

The amount of the load current can be set using an external analog control signal.

At the Analog I/O Port two inputs for the levels

0 ... 5 V for 0 ...  $I_{nom}$   
and 0 ... 10 V for 0 ...  $I_{nom}$

are provided.

The operating mode resistance supports no controlling.

To switch to the controlling by an analog signal push button "EXTERN".

The setting potentiometers are not effective for this situation.

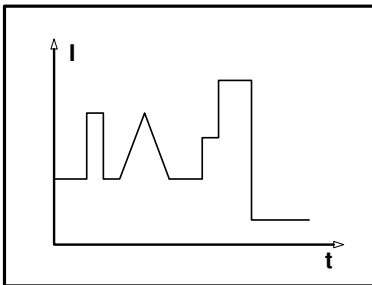

The load current setting occurs linear with the height of the control signal.

The device follows the set point with maximal controlling speed.

For reaching the maximum current a voltage of either 0 ... 5V or 0 ... 10V can be used.

At the Analog I/O Port the following pins are provided for the control signal:

EXT+ \_10 V      Pin 18  
EXT - \_10V      Pin 6

EXT+ \_5V      Pin 5  
EXT- \_5V      Pin 19

When setting the control voltage, take care to use the correct polarity!

The input resistance amounts to:

40 k $\Omega$  for the control input 10V  
20 k $\Omega$  for the control input 5V.



#### Ground Wire:

For using the analog control inputs there's often the danger of GND-loops.

Take care of the leading of the grounding wire for the control signal with reference to the negative load input, if you are using the analog control inputs.

The current flow over the load cables mustn't affect the control inputs. Otherwise there is the danger of an inexact current setting or self-oscillation.

To eliminate such problems the analog control input is realized as difference input.

The negative potential of the control inputs may vary at  $\pm 2V$  compared to the negative load input.

#### Pre-Setting:

When controlling the load current by the analog control input of the Analog I/O Port, the key SET/LOC shows, what current the voltage at the control input will set.

## 4.5 Battery Tests

For testing batteries and accumulators the device provides a settable discharge voltage.

When reaching the discharge voltage the discharge current is reduced. The device changes in a constant voltage operating mode and the over-discharging of the cells is avoided.

The battery test function is activated by connecting the following lines of the Analog I/O Port:

/VMIN:            Pin 17  
GND\_EXT:        Pin 1

If the line /VMIN is connected with GND\_EXT, the LED at the potentiometer for SETTING A blinks.

This potentiometer determines the discharge voltage. The potentiometer for SETTING B determines the discharge current.

Battery discharging can take place in the operating modes current and resistance as well as controlled by an external analog control signal.

Dynamic loads are not possible.

### Pre-Setting:

For presetting the load values the presetting function is used, that has been already described with the other operating modes.

For the support of presetting the discharge voltage a power supply unit can be used.

First the potentiometer for the discharge voltage is turned to zero (as far to the left as possible).

Afterwards the required discharge voltage for the unit under test is set at the power supply unit.

At the load the discharge current is adjusted using the potentiometer SETTING B.

Now potentiometer SETTING A is turned on until the current flow stops. By adjusting the potentiometer for this point the exact discharge voltage can be determined.

A second method for presetting the discharge voltage is the following calculation:

Calculate setting value  $I_x$ :

$$I_x = (U_e * I_{nom}) / U_{nom}$$

$U_{nom}$ : Nominal voltage of the device

$I_{nom}$ : Nominal current of the device

$U_e$ : Discharge voltage

$I_x$ : required current according the discharge voltage

### Example:

Device: PL312

$I_{nom}$ : 20 A

$U_{nom}$ : 120 V

Desired discharge voltage: 21 V

$$I_x = (21 \text{ V} * 20 \text{ A}) / 120 \text{ V}$$

$$I_x = 3.5 \text{ A}$$

For the setting first deactivate the battery discharge function, push the key SET/LOC and adjust the calculated value at the potentiometer SETTING A.

Now the battery discharge function can be activated.

#### 4.6 Operating Mode Voltage using the Battery Test Function

Using the battery test function the operating mode constant voltage can be adjusted.

Activate the **Battery Test Function** (see Battery Tests).

The potentiometer SETTING A has to be set to 0 to allow an operating down to the minimal voltage of the device.

The load is set using potentiometer SETTING B.

The potentiometer SETTING B will be turned on until the unit under test gets into current limitation.

When the voltage at the unit under test breaks down, the input voltage decreases down to the minimal voltage of the device.

Now this setting can be adjusted by turning on potentiometer SETTING A. By varying the voltage at potentiometer SETTING A different voltage points can be adjusted.

The voltmeter shows the adjusted voltage, the amperemeter shows the corresponding current.

When the sense terminals are connected, the voltage is controlled at the position where the sense terminals are connected to the output terminals of the unit under test.

#### 4.7 Loading up to Short Circuit

The devices with sense terminals (all 60V and 120V models) can load DUTs up to total short circuit using an external power supply.

The power supply must be able to supply the maximum load current of the application. The voltage should be about 2V or 3V.

You have to set battery test mode (see chapter 5.5). Potentiometer A must be set to 0. Potentiometer B adjusts the load current.

The power supply is connected as shown:

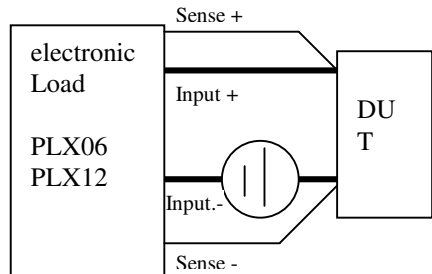

If potentiometer A is at 0, the current is reduced when reaching short circuit. At most the short circuit current flows.

If potentiometer B is opened maximum, the variation of potentiometer A simulates a voltage operation mode down to 0V.

## 5 Load on/off

The load is activated and deactivated using the switch "LOAD ON".

For the pushed position "On" the connected unit under test receives the load, for non-pushed position the load input becomes high impedance.

In the deactivated status the input resistance of the device amounts to  $>50k\Omega$ .

### Loading using the extern control input:

The activation and deactivation can also take place extern using a control input at the Analog I/O Port.

The control input "ON\_EXT" has to be set on GND.

The following pins of the Analog I/O Port are used:

ON_EXT:	Pin 4
GND_EXT:	Pin 1

This extern control input is connected to a switch at the front panel using an OR-function.

To realize the control function exclusively over the control input, the switch "LOAD ON" has to be deactivated.

## 6 Master/Slave Mode

To increase power or current the loads of the series PL can be switched parallel using the master/slave mode.



**The input voltage can't be increased by a serial arrangement!**

If different devices are used, the different ranges for power, current and voltage have to be considered.

At the slave devices the operating mode constant current has to be adjusted, and the slave device has to be set to "EXT".

The load terminals of the devices have to be connected to the unit under test. The setting of the devices occurs at the master device.

### Operating Mode:

The master device controls the current consumption of the slave devices and determines the operating mode.

If the master is in the operating mode current, all slaves follow the current operating of the master.

If the master is switched into the operating mode resistance, it controls also the current of the slaves, as if they were in the operating mode resistance.

When using devices with different current ranges or different power for the master/slave operating, it has to be taken in account, that this mode is only possible, as long as every device operates in the allowed operating range.

### Load Distribution:

When using only one device type for the parallel operating, every device carries the same current share as well as the same power.

For parallel switched devices with different current ranges in the operating mode master/slave, the device with the higher current range carries a corresponding higher share of the overall current.

For parallel switched devices with considerably differing current ranges the power can't be improved considerably.

The devices have to be connected like this:

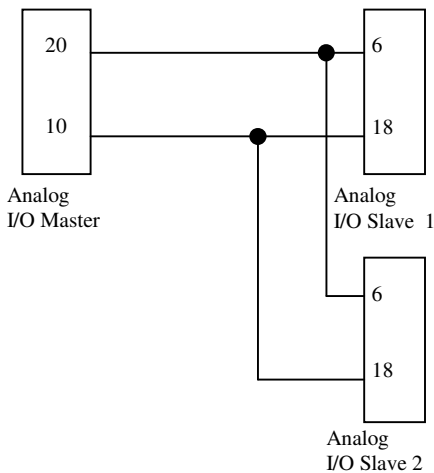

## 7 Analog I/O Port

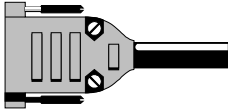

At the back panel a 25-pin Sub-D port provides different measuring and control lines.

At this port analog control signals for the connection of further measuring instruments can be read.

Another digital signal is provided for the recognition of a device. The device input can be controlled using this jack. The parallel switching of several devices takes place by connections at the analog I/O port.

**The inputs of the Analog I/O port must not exceed 125VDC against protective ground.**

**The cable at the analog I/O port should be not longer than 2m.**

### 7.1 Signals and Functions

#### Analog Measuring Outputs:

Signal	Pin	Direction	Level	Function
UPROP_E	22	Output	0 ... 10 V	voltage proportional measuring signal
IPROP_E	10	Output	0 ... 10 V	current proportional measuring signal
PPROP_E	9	Output	0 ... 10 V	power proportional measuring signal
MASTER	21	Output	0 ... 10 V	control signal for parallel switching
REF_EXT	8	Output	ca. 10.2 V	reference voltage
GND_EXT	7 20			GND for analog measuring signals

#### Trigger Functions:

Signal	Pin	Direction	Level	Function
/TRG_IN	3	Input	TTL-E	Trigger input for interface trigger functions
TRG_OUT	15	Output	TTL-A	Trigger output for dynamic loads
A/B	2	Input	TTL-E	Switchable input for load potentiometers SETTING A/B

**Sense Lines:**

Signal	Pin	Direction	Level	Function
SENSE -	13	Input	Input voltage	Leading line (sense) for the voltage measuring only by 60V- and 120V-devices
SENSE +	24	Input	Input voltage	Leading line (sense) for the voltage measuring only by 60V- and 120V-devices

**Analog Control Inputs:**

Signal	Pin	Direction	Level	Function
EXT+_5V	5	Input	0 ... 5 V	Control input for an external analog control signal 0 ... 5V
EXT-_5V	19	Input		GND for control input for an external analog control signal 0 ... 5V
EXT+_10V	18	Input	0 ... 10 V	Control input for an external analog control signal 0 ... 10V
EXT-_10V	6	Input		GND for control input for an external analog control signal 0 ... 10V

**Digital Control Inputs:**

Signal	Pin	Direction	Level	Function
/ON_EXT	4	Input	TTL-E	Control input for external load activation
/VMIN	17	Input	TTL-E	Switchable input for battery test function
GND_EXT	1			Ground for digital signals

**Digital Control Signals:**

Signal	Pin	Direction	Level	Function
STAT_OL	16	Output	OC	Status output for overload

**In-built Pull-Up Resistance**

Signal	Pin	Direction	Level	Function
/PULL_UP	14		5V	Pull Up Resistance 2.2 kΩ

### Not connected Pins

Pin	Function
11	Not connected
12	Not connected

Pin	Function
23	Not connected
25	Not connected

## 7.2 Allowed Levels:

Level	Description	Limits
OC	Open Collector	max. 30 V DC 100 mA
TTL-A	TTL Output	0 ... 5 V (internal Pull Up about 8 k $\Omega$ )
TTL-E	TTL Input	Level for Active High: 3 V ... 30 V DC

### 7.3 Connector Pin Assignment

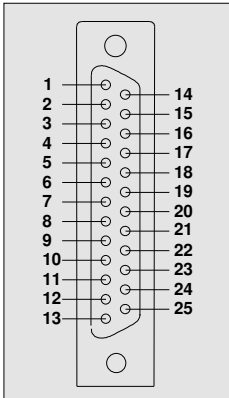

#### Attention!

Never connect a pin of the Analog I/O Port with the negative or positive input of the device!

The device could be damaged!

## 7.4 Analog Control Signals

### Voltage Proportional Measuring Signal "UPROP\_E"

The measuring signal "UPROP\_E" provides an analog voltage, that is proportional to the adjusted input voltage.

It provides 0...10V for an input voltage from 0 ... Unom of the device.

Detailed information is provided in the technical data sheet.

The measuring signal references always to the nominal input voltage of the device.

The current proportional measuring signal "Uprop" is provided at pin 22 of the port and is measured against GNDA\_EXT pin 7 or pin 20 of the port.

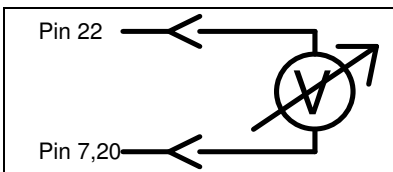

**The measuring output can be loaded with minimum 1k $\Omega$ .**

### Current Proportional Measuring Signal "IPROP\_E"

The measuring signal IPROP\_E provides an analog voltage, that is proportional to the flowing load current.

It provides 0...10V for a load current of 0... Inom of the device.

Detailed information about the accuracy is provided in the technical data sheet.

The current proportional measuring signal "IPROP" is provided at pin 10 of the port and is measured against GNDA pin 7 or pin 20 of the port.

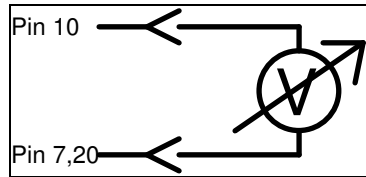

**The measuring output can be loaded with minimum 1k $\Omega$ .**

### Power Proportional Measuring Signal "PPROP\_E"

The measuring signal "PRPOP\_E" provides an analog voltage, that is proportional to the consumed power.

It provides 0...10V for a load consumption of 0...P<sub>MAX</sub> of the device.

P<sub>MAX</sub> is the short-term load consumption of the devices.

Detailed information about the accuracy is provided in the technical data sheet.

The power proportional measuring signal "Pprop" is provided at pin 9 of the port and is measured against GNDA pin 7 or pin 20 of the port.

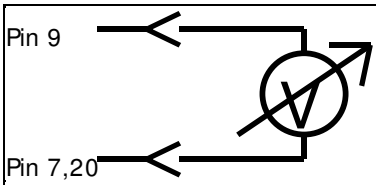

The measuring output can be loaded with minimum 1k $\Omega$ .

### Master Output "MASTER"

The measuring signal "MASTER" provides an analog voltage for adjusting the current set-point.

It is used as control signal for the master/slave operating of several devices. It provides 0...10V for a current range of 0 ... I<sub>max</sub> of the device.

The master signal "MASTER" is provided at pin 21 of the port and is measured against GNDA pin 7 or pin 20 of the port.

When the device input „LOAD ON“ is deactivated, the master signal provides a negative voltage of about -12V and causes the connected slaves to deactivate the current.

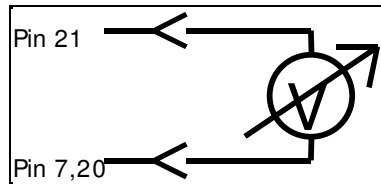

The measuring output can be loaded with minimum 1k $\Omega$ .

### Reference Output "REF\_EXT"

The measuring signal "REF\_EXT" provides a stable reference voltage of about 10.2V.

This voltage is provided for an external usage, for example the remote controlling using an external potentiometer.

The reference "REF\_EXT" is provided at pin 8 of the port and is measured against GND pin 7 or pin 20 of the port.

### Example for the remote controlling using an external potentiometer:

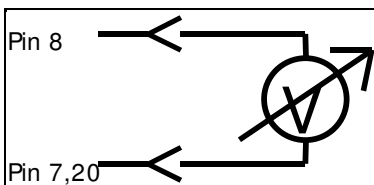
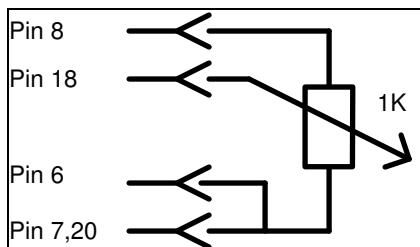

**The measuring output can be loaded with minimum 1k $\Omega$ .**

## 7.5 External Load Activation

The load activation and deactivation can take place over a control input of the I/O port.

Set the control input "ON\_EXT" as GND.

This external control input has to be connected to the switch at the front panel using an OR-function.

To set the control function exclusively over the control input, the switch "LOAD ON" has to be deactivated.

The switching of the load input can take place using different methods:

### a) by the normally open contact of an external relay (SPS etc.)

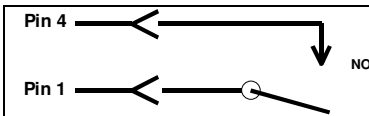

For a closed relay or switch contact the load input will be activated.

### b) by an activated transistor

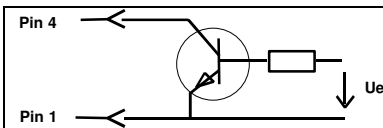

If the control voltage  $U_e$  is so high, that the transistor gets activated, the load input will be activated.

### c) by a logic output with active low

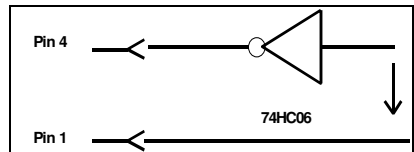

For a low-level at the gate the load input will be activated.

## 7.6 Status Signal for Overload

At the Analog I/O Port a output with open collector is provided (Pin16) . To receive a TTL Status Signal this output can be connected to the built in pull-up resistor (Pin 14).

The output will go HIGH as long as one of the following protection facilities is activated:

Over Temperature Protection	OTP
Over Power Protection	OPP
Over Current Protection	OCP
Over Voltage Protection	OVP

## 8 Protection Facilities and Overload Display

Several protection facilities have been realised to protect the device against overload. They prevent the damaging of the device, if it's operated incorrectly or if the unit under test is defect. The following protection facilities are provided:

- **Current Limitation**
- **Power Limitation**
- **Over Voltage Protection**
- **Transient Protection**
- **Over Temperature Protection**
- **Reverse-Connection Protection**
- **Under Voltage Recognition**

If one of the protection facilities is triggered, this will be signaled by a blinking voltage and/or current display.

At the Analog I/O Port a control signal is provided, that signalizes the overload of the device. (Detailed description see Analog I/O Port)

### Overview Overload Display

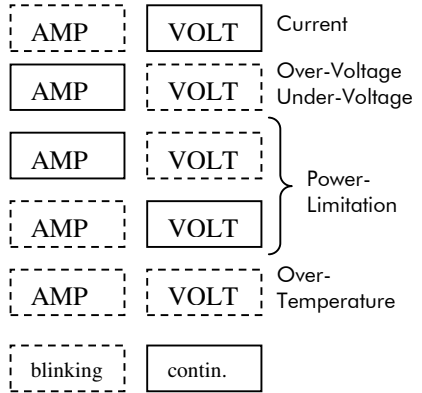

### Current Limitation

In the operating mode resistance the in-built current limitation can be triggered.

The current limitation is activated, when the load current amounts to about 110% of the set current range.

The device limits the current to the maximum allowed value and continues as soon as the current is back in the nominal range.

If the current limitation takes place, the current display blinks.

### Power Limitation

To protect the in-built power unit the power limitation observes the consumed power and limits the load current to the allowed value. This value is dependent on the temperature of the power unit.

For a cold power unit (heat sink temperature  $< 21^{\circ}\text{C}$ ) the power limitation allows upto 3.3 times the nominal power of the device.

For increasing temperature the load-bearing capacity of the device decreases down to the nominal value, that can be realized continuously for  $21^{\circ}\text{C}$ .

If the allowed power is exceeded, the voltage and current display blink alternately.

In this state the device decreases its current consumption until the allowed power is no longer exceeded.

### Over Voltage Protection

The device is protected against over-voltage upto 20% of the nominal voltage range.

When reaching the maximal allowed input voltage, the device begins to take

current from the connected voltage source, to prevent a further rising of the voltage.

In this operating range the device behaves like a zener diode and can take current, until its maximum load-bearing ability is reached.

Over-voltage is signaled by a blinking voltage display.

### Transient Protection

Transient overvoltage peeks are limited by in-built suppressor diodes.

These diodes can handle a maximum energy of 600 mWs and are able to suppress voltage peeks resulting of switching operations at the load terminals.



**Higher energy or a continuous overvoltage can destroy the device.**

### Over Temperature Protection

For the protection of the in-built power semiconductors there's a semiconductor temperature sensor implemented on every cooling bar, that constantly measures the temperature.

If the temperature exceeds the allowed maximum value of 120 °C, the current is shut down.

This state is signalized by simultaneous blinking of current and voltage display.

After cooling the power units the current will be reactivated.

### Reverse-Connection Protection

The input is protected against reverse-connection of the connector terminals. In such a case the input voltage will be short-circuited by a diode function. The resulting short circuit current mustn't exceed the allowed continuous current of the device.



**Higher short-circuit currents can destroy the device.**

The sense connections (provided for devices upto a nominal voltage of 120V) are protected against reverse-connection.

### Under Voltage display

Under voltage is recognized, when the input voltage of the device is too low to keep the set load.  
The voltage display blinks.

## 9 Load until Short Circuit

For devices with sense connections (up to 120 V) a loading of voltage sources until a full short circuit can be realized using an external current supply.

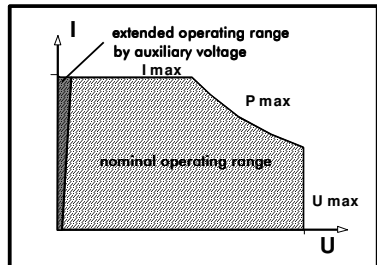

The external current supply is used to compensate the minimum voltage of the load.

The current supply must be able to provide the maximum current of the load (or at least the maximum current that will be set).

The output voltage has to amount to a value which compensates the minimum voltage of the load (i.e. about 2V).

The output voltage of the additional current source must not be too high, because the load has to consume the product of voltage and set current as additional dissipated power.

Please notice that the load doesn't consider this support voltage and though can't recognize the corresponding power increase.



**When using a support voltage for loads up to short circuit the maximum load of the device must not be exceeded.**

The general power is calculated as

$$P_{\text{gen}} = (U_{\text{UUT}} + U_{\text{aux}}) \cdot I$$

In this way the device can be used to acquire current limitation characteristics until full short circuit.

**The devices has to be connected as shown in the following figure:**

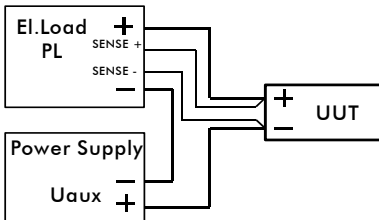

The unit under test and the auxiliary power supply are connected in series. The sense lines are lead across the auxiliary power supply to the output of the unit under test.

Select the operating mode **Battery Test Function** (see Battery Test).

The potentiometer **SETTING A** (discharge voltage) has to be set to zero to allow operating until short-circuit.

The load is set using potentiometer **SETTING B**.

The discharge voltage function of the device prevents that the voltage of the unit under test is reversed.

When reaching Zero Volt the current is reduced down to short-circuit current, so that the voltage is controlled. A further increasing of the current setting causes no increasing load current for the case of short circuit.

### Measuring Characteristic U-I Curves

If the load current is set higher than the short-circuit current, several voltage points can be set by varying the discharge voltage at the potentiometer **SETTING A**. The corresponding load current is shown at the ammeter.

In this way it's possible to simulate the operating mode „Constant Voltage“.

In the operating mode resistance it's not possible to load up to full short circuit, because a resistance setting down to  $0\Omega$  is not possible.

When the sense terminals are connected, the short circuit is controlled up to the position where the sense terminals are connected to the output terminals of the unit under test.

That means, the resistance of the load cables will be taken in account and controlled.

The load terminals even can get slightly negative to compensate the power loss at the load cables.

In this way it's even possible to set a real short circuit using longer cables, what's not possible by power switches.

## 10 19" - Fitting

For the assembly of the devices in a 19" rack several assembly kits are provided.

### **One Device, ½ 19" (PL3XX)**

To fit a device with ½ 19" in a 19" rack, the assembly kit ESPL05-1 is used to widen the device.

The assembly kit is mounted according the following steps:

1. Decide, whether the device shall be on the left or on the right side of the rack.
2. Remove the feet of the device.
3. Remove the screws of the lid at the side where the widening has to be installed.
4. Mount the widening using this screws.
5. Fasten the provided frames with the grip at the widening side.
6. Remove the front screws of the lid at the other side.
7. Mount the second frame with these screws.

### **Two devices with each ½ 19" Width (2 PL3XX)**

To fit two devices with each ½ 19" in one 19" rack the devices have to be connected using the assembly kit ESPL05-2.

Follow these steps:

1. Remove the feet from both devices.
2. Mount the connection plates using the supplied screws M4 x 6mm.
3. Remove the front screws of the lid.
4. Mount a frame at the left and at the right using this screws.

### **One Device 19" (PL6XX or PL9XX)**

For the assembly of a device with 19" width the assembly kit ES PL2 is used.

The assembly kit is mounted according the following steps:

1. Remove the front screws from the lid of the device.
2. Mount frames at the left and at the right using these screws.

## 11 Troubleshooting

### 11.1 Stability Problems by Fulfilling the Resonance Condition

When testing power supplies or other circuits that stabilise an output quantity using a control loop, two controllers are connected when connecting the electronic load.

Under certain conditions, i.e. when the phase shift is higher than  $180^\circ$  and the amplification is greater than 1, the resonance condition is fulfilled and the system begins to oscillate.

This state is no fault of the electronic load, but a normal state – but not desired for test situations.

This state can be compensated by interrupting the pre-requisite for the resonance condition.

In practice it's possible to fit a capacitor parallel to the load input.

Sometimes a small MKT capacitor of about  $1\mu\text{F}$  realises a stabilisation.

Loading voltage sources with inductive impedance (like transformer with rectifier but without capacitors) can also cause stability problems, because the inductance itself works current regulating.

The current can only be regulated by one device (inductance or electronic load) therefore instability can occur.

### 11.2 Couplings by Current Lines

Especially in the operating mode resistance it's possible that there is an in-coupling of the current leading load cables affecting the voltage measurement of the device, when using sense lines.

As in the operating mode resistance the exact measurements of the voltages at the unit under test are used as set point for the current, a magnetic coupling in the sense line can cause the system to become instable.

As a first step decrease the coupling:

**Separate the sense lines from the current leading load lines (and of course all other current leading cables, power lines etc.)**

The best method is to twist the sense lines to compensate the magnetically induced voltage.

**Never twist the sense lines with current leading lines!**

The current leading lines could be twisted too, or should be at least lead parallel, so that the magnetic fields are compensated partly.

And of course:

**Keep all lines as short as possible.**

If those measures don't remedy the problem, try to fit a blocking capacitor for the sense lines at the Analog I/O Port.

### 11.3 Distorted Current Rise for Dynamic Operating

To reach the best current rise in the dynamic operating mode, several conditions have to be fulfilled:

- a) The dynamic internal resistance of the voltage source has to be very low. For the quickest possible current change the load can't additionally react on changes in the voltage source.
- b) The resistance of the external lines has to be very low (see a)).
- c) The external lines have to be free from inductions. Inductive external lines (every cable has got an inductive component) result in combination with the ohmic resistance in a limitation of the maximal possible current rise time. The load can't react on a fast current rise, when the connecting cables reduce the speed. Moreover, the external lines act als energy storage (self induction) and supply current in the load and the unit under test, when the load is released.

#### 11.4 Measuring the Current Rise Time

The measuring of the rise times must happen using a clip-on probe of sufficient speed (for example Tektronix Current Measurement)

The current measuring using shunts results often in wrong values, because the most measuring shunts are not free of induction.

Such measurings inevitably result in slower rise times with considerable overshoot.

#### 11.5 Distorted Anlaog Measurement Signals

Especially for the testing of pulsed current supplies it can happen, that the measuring signals for voltage, current etc. at the Anlaog I/O Port are distorted.

The reason is founded in the construction of the measuring circuit.

Pulsed current supplies have got filters in the output circuit, including so-called Y-condensators, that are switched from the output to the grounding wire of the device.

Moreover, the electronic load and other measuring instruments contain filters (EMV).

Because of the Common Mode disturbing voltage (voltage, that both output connections of the current supply have against the grounding wire) a fault current flows through the fault clearance condensator crossing the load or connected measuring instruments back to the load output.

This disturbing current often results in high frequency overlays at the measuring signals.

Especially high disturbing voltages are caused for dynamic tests.

Supply the electronic load and/or the further connected measuring instruments with low coupling capacity using an isolating transformer. The disturbing current circuit will be interrupted and the quality of the measuring signals gets better.



## Declaration of Conformity

This declaration is valid for following product:

**Equipment:** **Electronic Load**

**Type:** **Series PL**

Hereby the equipment is confirmed to comply with the requirements set out in the Council Directive on the Approximation of the Laws of the Member States relating to Electromagnetic Compatibility (89/336/EEC) and the Council Directive relating to Low Voltage 73/23/EEC.

The following company is responsible for this declaration.

**Höcherl & Hackl GmbH**  
**Industriestraße 13**  
**94357 Konzell**

The measurements were carried out in accredited laboratories.

For the evaluation of above mentioned Council Directives for Electromagnetic Compatibility and for Low Voltage following standards were consulted:

DIN EN 61326  
DIN EN55022  
(DIN EN 61000-4-2, DIN EN 61000-4-3,  
DIN EN 61000-4-4,  
DIN EN 61000-4-5, DIN EN 61000-4-6,  
DIN EN 61000-4-8  
DIN EN 61000-4-11)  
DIN EN 61000-3-2  
DIN EN 61000-3-3  
DIN EN 61010-1

Konzell, 10.01.2005

Place, Date

Signature of responsible Persons

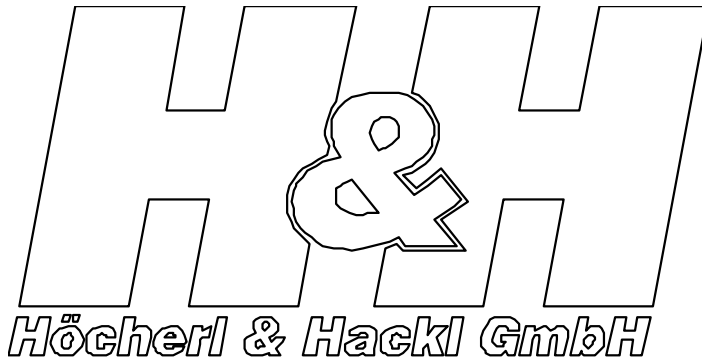

**Schulz-Electronic GmbH**  
Dr.-Rudolf-Eberle-Straße 2  
D-76534 Baden-Baden

Fon +49.7223.9636.0  
Fax +49.7223.9636.90

vertrieb@schulz-electronic.de  
www.schulz-electronic.de

**Schulz Electronic**  
Professional Power Supplies