

Installation Manual

DC/DC converters

PSE100, PSE150, PSE200, PSE250



PSE100
PSE150
PSE200

PSE250
or option
T3



PSE with option N wall DIN and chassis mounting



H15-S connector
Connector holder for
option N



Schulz Electronic
Professional Power Supplies

Schulz-Electronic GmbH
Dr.-Rudolf-Eberle-Straße 2
D-76534 Baden-Baden

Fon +49.7223.9636.0
Fax +49.7223.9636.90

vertrieb@schulz-electronic.de
www.schulz-electronic.de

Polyamp AB
Box 925
191 29 SOLLENTUNA
Sweden

www.polyamp.com
info@polyamp.se
Tel: +46 859469300
Tel: +46 859469305

EU VAT no SE556103276301
DUNS no 35-430-3372
CAGE S4231
NCAGE S4231

Warranty

All Polyamp DC/DC converters are warranted against defective material and workmanship. This warranty is valid for 24 months from the date of delivery. We will repair or replace products which prove to be defective during the warranty period. The warranty is valid only if the converter is used within specification.

Manual

This manual is as complete and actual as possible at the time of printing. However, the information may have been updated since then. Polyamp AB reserves the right to make changes in this manual without notice.



The exclamation point within an equilateral triangle is intended to alert the user to presence of important operating and maintenance instructions in the literature accompanying.



The lightning flash with arrowhead, within an equilateral triangle, is intended to alert the user to presence of uninsulated "dangerous voltage" within the products enclosure that may be of sufficient magnitude to constitute a risk of electric shock to persons.

Caution!

To prevent the risk of electric shock, do not open enclosure. No serviceable parts inside. Refer servicing to qualified service personnel only.



We supply a separate declaration of conformity within our shipment that mainly refers to the Low voltage directive and EMC directive.



CONTENTS

1	Before installation	4
1.1	Cable and pin dimensioning.....	4
1.2	Reverse input voltage protection	5
1.3	Input Fuse.....	5
1.4	Inrush current limit	5
1.5	Series diode on input, option K1.....	6
2	Installation.....	6
3	Parallel connection	7
3.1	Series diode on the output, option C.....	7
3.2	Series diode with series resistor, option CR	7
3.3	Output under voltage alarm	8
3.4	Connecting systems in N+1 configuration.....	8
3.5	Connecting converters in parallel on the output	8
3.6	Adjusting output voltage when units are paralleled on the output.....	9
4	Multiple loads at the output.....	10
4.1	Short circuits	10
5	Output voltage sense, option S.....	10
6	Output over voltage protection OVP.....	11
6.1	Standard feature	11
6.2	OVP option A	11
7	Output low voltage alarm.....	11
7.1	Logic signal alarm.....	11
7.2	Relay output alarm, option B	11
8	Higher isolation voltage, Option E1 & E2	12
9	Isolation voltage test.....	12
9.1	DC isolation test output to case	12
9.2	AC isolation test output to case, option E2.....	12
9.3	DC isolation test input to output and input to case	13
9.4	AC isolation test input to output and input to case (Option E1).....	13
10	Trouble shooting	14
10.1	There is no output voltage.....	14
10.2	The input fuse blows when the input is connected.....	14
10.3	The converter starts and stops repeatedly	14
10.4	Fault report	14

1 Before installation

Before installation, please read this section and minimum section 2. This installation manual shall also be read together with the datasheet of the product. Download the datasheet from www.polyamp.com and check the File archive where in section Datasheet you will find PSE100.pdf and PSE250.pdf. If any problem occurs during installation please check section 11 *Trouble shooting*.

The product is labelled as below example:

<p>PSE100B24 Input range: 20 – 72 Vd.c. 6.5 A Output: 24V 4.2A Option: L, C</p>
--

The DC/DC converter type name consists of model name PSE100, PSE150, PSE200 and PSE250 followed by input code and output voltage. Two examples:

- "Type: **PSE100B12**" has input code "B" and nominal output voltage **12 Vd.c.**
- "Type: **PSE250 110/24**" has input code "110" and nominal output voltage **24 Vd.c.**

The **Options** are block letters separated by comma(.). You will find explanation within this manual what the letter code means. The **input** states the nominal input voltage and **maximum input current** at any conditions. It means the output is adjusted +10% above nominal voltage and close to the current limit, which is the stated output current +5% and a lowest input voltage level.

Input range is the input range that the unit can operate normally.

Output indicates the nominal output voltage and the rated current.

The output is current limited with a so called rectangular characteristic. When the current limit is reached, which is adjusted to +5% of above mentioned nominal output current, this is the maximum current that will continuously flow. The output voltage drops very quickly down towards zero volt (depends on the series resistance of the load circuit as the unit can be regarded as a constant current generator at over current condition). We have no time limit on over current condition.

Temperature range is the rated operation temperature at 100% load condition.

Input, output and case are galvanically separated from each other. You can thus choose how you want the system connected. This is a **Class I insulation system**, which is dependent of correct earth connection on the input. All outputs are insulated from case with minimum 2000 Vd.c. *Section 10 Insulation voltage test*, describes the insulation rating depending on input voltage. See *section 9* if higher insulation is required.

Series number is stamped on the panel under the connector.

1.1 Cable and pin dimensioning

The PSE series is using a DIN 41621 H15 connector intended for 3HE Euro format mounting. Each pin has a continuous current rating of 15A @+55°C and 12A @+70°C ambient temperature.

The **Uout** pins are internally parallel connected and can therefore supply more current or two different loads. If the unit is equipped with sense option S this must be connected to one of the loads or a distribution point.

1.2 Reverse input voltage protection

The input is protected against reverse polarity by a parallel diode on the input on all models. The parallel diode is dimensioned to blow a fuse.

Reverse voltage protection with series diode, see section 1.5 Series diode on input, option K1.

1.3 Input Fuse

The input shall be fused with an approved fuse with a slow blow characteristic and high breaking capacity. See Table 1 and 2.

Input voltage code	Slow blow fuse PSE100
A	16 A
B	8 A
C	3.15 A
D	1.6 A

Table 1. Fuse dimension PSE100

Input voltage code	Slow blow fuse PSE150	Slow blow fuse PSE200	Slow blow fuse PSE250
24	10 A	15 A	20 A
48	5 A	8 A	10 A
110	3 A	4 A	6 A
220	1.5 A	2 A	3 A

Table 2. Recommended input fuses.

There are two reasons why we do not include the fuse:

1. DC-networks should be fused at the distribution point to protect the cable.
2. Different applications require different types of fuses.

A switching device able to switch off both polarity input cables has to be mounted externally. The switching device shall be marked accordingly and easy accessible. In case the fuse is activated at start-up the fuse need to be dimensioned for longer time delay or order inrush current limit, see option H next section.

1.4 Inrush current limit

The input capacitors are charged through an NTC resistor to reduce the input current during start up. On input code D and 220 the NTC resistor is standard.

As an **Option H** the NTC resistor can be provided on models with input codes B, CT, C, and 110.

All models has an "output soft start" that do not increase the input current above the unit rated current during start up (approx.. 0.1s).

Start-up behaviour with NTC resistor on DC inputs.

The input voltage range is changed when an NTC resistor is used, see Table 3. The reason is due to sudden load changes from 0 to 100%, the input current also changes abruptly. This will cause a voltage drop across the NTC resistor (until it heats up). If the input voltage is only slightly higher than the start voltage of the converter this voltage drop will cause the converter to stop. The converter will then start and stop several times until the NTC resistor is heated up. We have therefore increased the lowest input voltage on units with a NTC resistor so this behaviour not arises.

PSE (normal input voltage range)	
Input voltage code	Input voltage range
B	20 – 72 Vd.c.
C	50 – 150 Vd.c.
D	90 – 270 Vd.c.

PSE with option H	
Input voltage code	Input voltage range
B	30 - 72 Vd.c
C	75 - 150 Vd.c.
110	75 - 150 Vd.c.
D	115 - 270 Vd.c.

Table 3. Input voltage range with and without option H

The unit starts if the voltage is within the normal input voltage range, but depending on the load (if the NTC is heated up) a load change might cause the converter to stop and start as described before.

1.5 Series diode on input, option K1

Series diode on input is used of two reasons; as reverse voltage protection and if hold-up time is specified. Depending on input voltage the unit will be derated due to the diode losses. A series diode as reverse voltage protection is recommended if long distance between input fuse and unit input (>3 m).

2 Installation

The converter is designed to be mounted in a 3U 19" sub rack unit. Otherwise a location only accessible for service, which meets the demand of EN60950 regarding fire enclosure, voltage hazard protection and mechanical strength shall be used. With option N, wall mounting set you can mount the converter in any direction on a wall or with optional mounting clips on DIN rail TS35. The converter is convection cooled and in order to get sufficient cooling there shall be a free air around the converter. If this is not possible, we recommend the use of an external fan.

On 5 V single output voltage the case temperature might increase +20 °C above ambient temperature. An optional extra cooler, called T3, can be provided on 5 V versions to lower temperature or increase the operating temperature range. The extra cooler is called T3.

Note that the expected life of the converter is dependant on converter temperature. As a rule of thumb, for every 10°C that the temperature is lowered the expected life is approximately doubled. It is therefore crucial to cater for good ventilation and if possible to reduce ambient temperature.

To meet the EMC specifications in the enclosed "declaration of conformity" use twisted-pairs for connecting input, output and alarm. Shielded cables are not necessary.

If the converter supplies a DC-motor, we recommend an external parallel diode at the motor poles to protect against reverse voltages.

If the converter is mounted in an electric vehicle, an external series diode on the input is recommended. Please contact your Polyamp dealer. See also *section 1.5 series diode on input, option K1*.

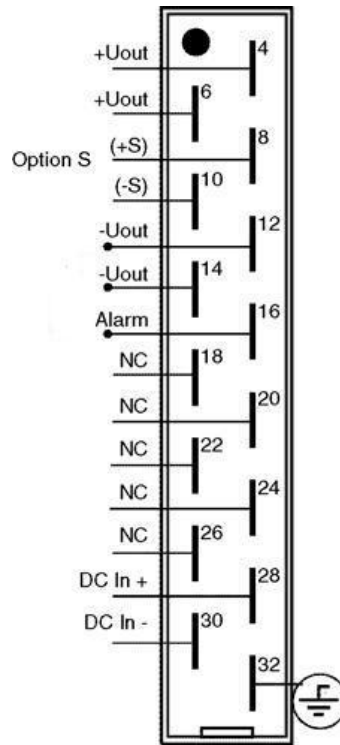

Figure 1. Pin out DIN41612 H15 connector.

Installation in a 19" sub rack :

1. Check the *pinout with Figure 1*. Connect the protective earth pin 32. This provide safety against electrical shock and is required to achieve EMC performance according to the declaration of conformity.
2. Be aware that if the sense option "S" is provided the sense must be connected to the sensing point and cannot be left open, *see Section 4 page 10*.
3. Plug in the unit. Read from bullet 3 below.

Installation with wall mounting panel option N:

1. Check the *pinout with Figure 1*. Connect protective earth to pin 32. This provide safety against electrical shock and is required to achieve EMC performance according to the declaration of conformity.

2. Connect the output. Be aware that if the sense option "S" is provided the sense must be connected to the sensing point and cannot be left open, *see Section 6 page 10*. Bundle the output cables together, separate from input.
3. The converter output is short-circuit proof by a constant current limit which works unlimited in time. Therefore there is no need to fuse the load (unless you use multiple loads, see below). The current limit is fixed to 105% of nominal output current.
4. Features and options
 - If the converter is to be connected in parallel at the output, please *consult page 7-9*.
 - If you use multiple loads, please *consult page 10*.
 - If you intend to use output undervoltage alarm options, please *consult page 11*.
5. Connect the input cables. Bundle input cables together separated from the output cables.
6. Start the converter by inserting your input slow blow fuse to your DC voltage supply. Sparks may occur when the input capacitors are charging.

Beware of hazardous voltages!

The output voltage can be adjusted $\pm 10\%$ of nominal output voltage with the potentiometer marked V.ADJ on the front panel. Clockwise turn increases the output voltage. The potentiometer has 15 turns. If you have connected units in parallel on the output, the procedure of adjusting the output voltage is described in *Adjusting output voltage when units are paralleled on the output* on page 9.

3 Parallel connection

If a redundant power supply system is requested, two or more converters can be connected in parallel. To achieve redundancy the number of converters must be dimensioned to carry the whole load even if one converter is faulty. The option C or CR series diode on the output must be provided. Connect your load to the + output after the series diode (cathode). Do not forget to fuse the inputs separately to achieve redundancy.

Another reason for connecting two or more converters in parallel is to get more power. The option C must be provided and use the output with series diode. When the series diode C or CR option is used the *Sense option S*, *see section 4 page 10*, cannot be used.

3.1 Series diode on the output, option C

A series diode is necessary if the output is connected in parallel with another power supply or if you require redundant operation. If a converter breaks down with an internal short-circuit on the output and other converters are connected in parallel on the output, the broken unit will short-circuit the others if the series diode is not used. This might cause excessive heat or even fire in the faulty unit.

The series diode protects the converter output from external voltage sources.

3.2 Series diode with series resistor, option CR

This option is an extension of *3.1 Series diode*. When several PSE units are connected in parallel with so called "hot plug in" in 19" sub-rack, a built in series resistor and series diode is provided that will automatically balance the current between units.

The series resistor will provide the Ud function described in *section 3.6 and Figure 4*. Thus no special cable arrangements are needed with this CR option.

3.3 Output under voltage alarm

If one DC/DC converter fails in a redundant power system an alarm signal should be detected.

The PSE has a logic signal alarm. An optional relay dry contact output is also available as an option, *see section 8 page 11.*

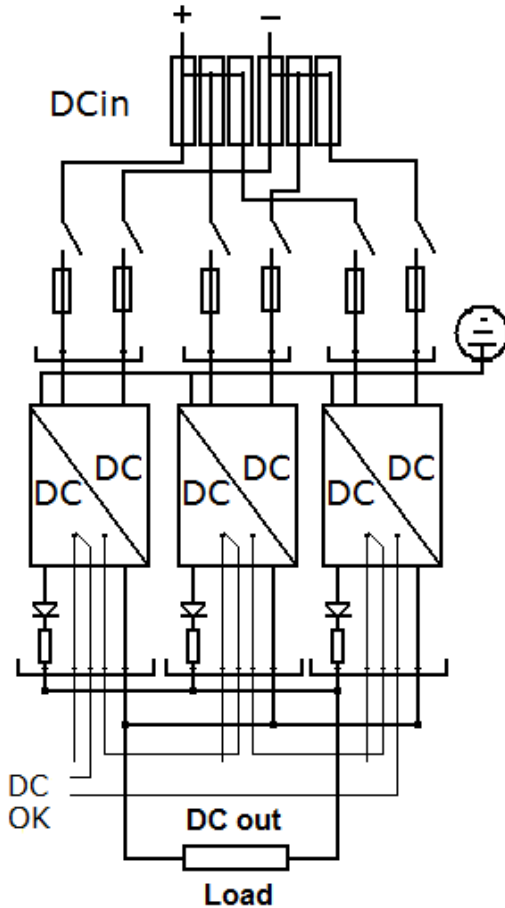

Figure 2. An N+1 system with two units for the load and one for the redundancy.

3.4 Connecting systems in N+1 configuration

The *figure 2* shows a N+1 system with two units for the load and one for the redundancy. Each Power supply has a built in; series diode (C), balancing resistor (R) and alarm Relay option B. The alarm is cascade connected. Note that each DC/DC converter has individual external input fuses. With the CR option a hot plug-in can be achieved if the output voltage is correctly adjusted. Use instruction *section 3.6 -3 below.*

3.5 Connecting converters in parallel on the output

The expected life of the converter is dependant on converter temperature. It is therefore important for paralleled unit to share the load as equal as possible to reduce the converter temperature. To achieve good current sharing the converters must have separate cables to the load.

The cables should be dimensioned to have a voltage drop, U_d , between the converter and the load at maximum current capacity, *see Figure 3 and Figure 4.*

- When the series diode is used, which we recommend, the voltage drop should be approximately 1.0% of nominal output voltage (to also compensate for the negative temperature coefficient of the diode).
- When the series diode is **not** used, **this is not recommended**, the voltage drop should be approximately 0.5% of nominal output voltage.

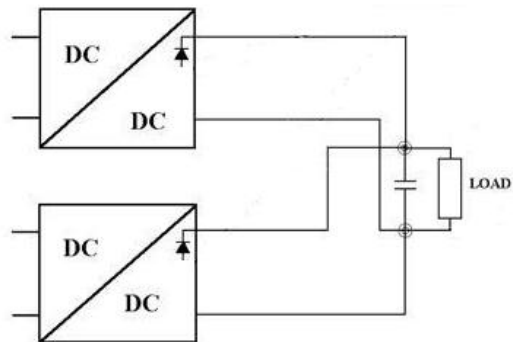

Figure 3. Paralleled system, where cables produce voltage drop and a voltage stabilising capacitor in proximity of the load.

Note that the voltage drop affects the load regulation (the voltage at the load), *see Figure 4.*

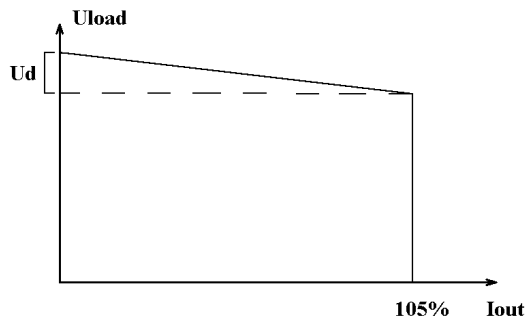

Figure 4. Load regulation with voltage drop U_d between output and load

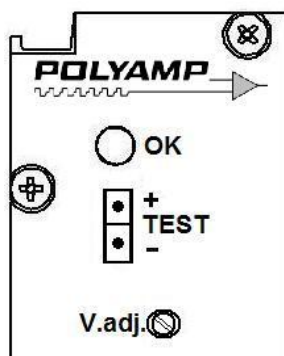

Figure 5. Output voltage measurement point before the series diode accessible from frontpanel.

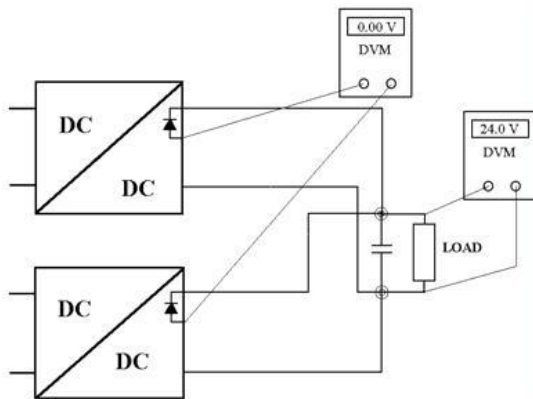

Figure 6. Adjusting output voltage measure at +Test or pin 8 on the H15 connector.

3.6 Adjusting output voltage when units are paralleled on the output

1. Connect and start all converters according to *Installation* on page 6. We recommend using the series diode and separate cables as mentioned above in 3.4 *Connecting converters in parallel on the output*.
2. Measure the voltage at the load. Connect voltmeters as showed in *Figure 6*. If you have only access to one voltmeter you must move it around to make the adjustments.
3. To **increase** the output voltage. Increase the output voltage by turning the potentiometer marked "V.ADJ" clockwise on the unit with the lowest output voltage until you reach the desired voltage at the load or until the output voltage does not increase anymore (as the unit is in current limit). To find the unit with the lowest output voltage you can measure the voltage difference before the series diode, as in *Figure 6*. Repeat from i. until you reach the desired output voltage at the load.
4. To **decrease** the output voltage.
 - i. Decrease the output voltage by turning the potentiometer marked "V.ADJ" counter clockwise on the unit with the highest output voltage until you reach the desired voltage at the load or until the output voltage does not decrease anymore (as the other units supply all current). To find the unit with the highest output voltage, measure the voltage difference before the series diode, as in *Figure 6*.
 - ii. Repeat from i. until you reach the desired output voltage at the load.
5. To achieve good current sharing, adjust all converters so that the voltage difference before the series diode is 0.00 V between all units that are connected in parallel and so that the voltage at the load is still the desired.

4 Multiple loads at the output

If you are using several loads, we recommend fusing them separately with fast acting fuses. Some considerations regarding short circuits should be taken. See below.

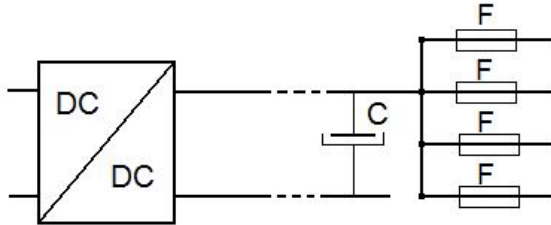

Figure 7. Connecting multiple loads.

4.1 Short circuits

1. If there is a short circuit in one branch and the total current in all branches **does not exceed 105%** of the nominal current of the converter (see label on front panel), the output voltage will not be affected. The time for the fuse to blow can be calculated from the data sheet of the fuse if you know the short circuit current through the fuse.
2. If there is a short circuit in one branch and the total current in all branches **does exceed 105%** of the nominal current of the converter, the output voltage will drop until the fuse is blown. Depending on the impedance of the short circuit (whether it is abrupt or merely an overload) and the resistance of the load cables, the effects of a short-circuit will vary.
3. Long cables reduce short circuit currents, resulting in longer delay until the fuse is blown and hence an increased voltage dip. Light overload does not necessarily result in a blown fuse.
4. To reduce the voltage drop at short circuit and if any branch has more than approximately 30% of the total output current of the converter, a large external capacitor is recommended. Such a capacitor will supply the peak current needed to blow the fuse, *see Figure 7*.
5. To calculate the capacitor needed, use the following formula:

$$C = 1.2 \times (IS \times \Delta t) / \Delta U$$

1.2 = Safety margin

IS = Short-circuit current through the fuse.

Δt = Time before the fuse blows (see data sheet on the fuse).

ΔU = Acceptable voltage dip before the fuse blows.

Example:

You have a 1A fuse with fast characteristic and the short circuit current is 10A. The datasheet gives you that $\Delta t = 10\text{ms}$. The output voltage is 24V, and you can accept 10% voltage drop $\Rightarrow \Delta U = 24 \times 0.1 = 2.4\text{V}$.

The capacitance you need is:

$$C = 1.2 \times (IS \times \Delta t) / \Delta U = 1.2 \times 10 \times 0.01 / 2.4 = 50,000\mu\text{F}$$

Select a capacitance with a rated voltage of at least 115% of nominal output voltage of the converter.

Repeat this calculation for all branches and choose the highest capacitance value.

It is sometimes difficult to estimate the short-circuit current when the nature of a fault is unknown. In this case a voltage dip might appear under some shortcircuit conditions even with a large capacitor present. If a voltage dip is critical in one branch it is recommended to use a separate DC/DC converter supplying this branch.

5 Output voltage sense, option S.

The remote voltage sense is used to improve the regulation at the load. The voltage regulation is moved to a point outside the converter where the sense is connected. Longer sense leads than 3 m is not recommended. The voltage difference between the load and the converter should not be larger than the output voltage range. Use twisted sense wires, *see Figure 8*.

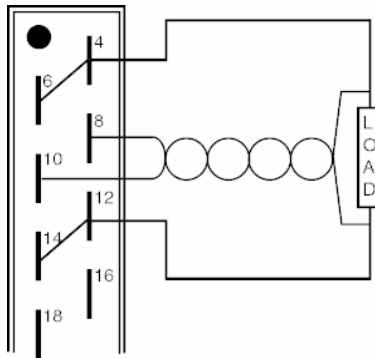

Figure 8. Remote sense connection.

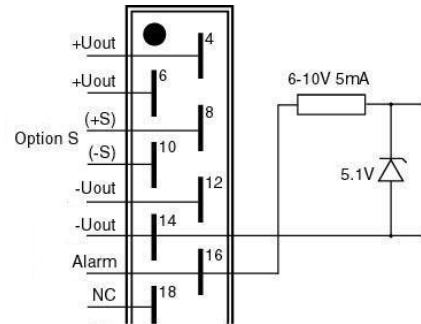

Figure 9. UL Alarm with 5V logic signal.

6 Output over voltage protection OVP

6.1 Standard feature

In case the regulation circuit fails on the output, a secondary regulation circuit limit the output voltage level. The circuit also protects the converter output from external voltages. OVL trigger voltage is set to 115% to 120% of the nominal voltage. The circuit is active as long as the over voltage condition remains.

6.2 OVP option A

An independent circuit using a SCR thyristor is used as over voltage protection. When activated it short circuits the output. Reset a triggered OVP by switching off and on the input voltage.

The circuit protects the converter from high external voltages as well as regulation failures of the unit. The OVP trigger voltage is set to 115% to 120% of the nominal voltage. OVP is standard on all 5 V master outputs and will trigger at max. 6.2 V.

7 Output low voltage alarm

The alarm circuit monitors the output voltage and trigger when the output voltage become below -10% of nominal output voltage.

7.1 Logic signal alarm

A standard unit is equipped with a logic signal. DCOK or POWER GOOD signal use logic 1. The drive voltage is 6 to 10 V, 5 mA = logic 1. See also Figure 9.

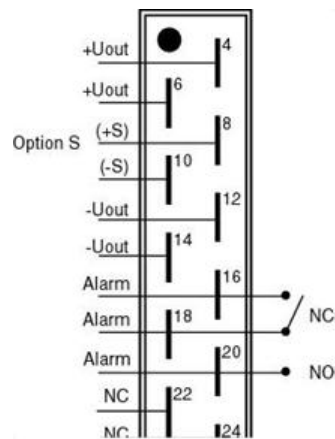

Figure 10. UL alarm with internal relay, option B. Relay symbol shows Alarm state.

7.2 Relay output alarm, option B

The alarm has dry contact output with selectable NO, NC function. The relay output is insulated from both input and output 2.5 kVa.c., see Figure 10.

The relay is rated 30V 0.5A (a.c. & d.c.). For higher voltage/current relay rating please contact Polyamp.

The alarm relay can be connected in two ways:

1. Normally Open (NO).
Connect twisted-pair (0.25 mm² -0.5 mm²) from centre pin of the removable alarm connector and connector pin marked "NO".
2. Normally Closed (NC).
Connect twisted-pair (0.25 mm² - 0.5 mm²) from centre pin of the removable alarm connector and connector pin marked "NC".

8 Higher isolation voltage, Option E1 & E2

E1 is 2 to 2.5 kVa.c. 1 minute between input and output, input and case. Only applicable for A, B, 24, 48 input codes.

The emission level is increase to level A.

E2 is 2 to 2.5 kVa.c. 1 minute between output and case. The emission level is increase to level A.

9 Isolation voltage test

Each converter has been isolation tested in factory before delivery. Please note that consecutive insulation test damage the Y-capacitors and affect the EMC performance of the unit. We ask you therefore to minimize or completely avoid such test.



Warning!



An isolation test shall only be performed by personnel aware of the dangers and hazards of the test.

The isolation voltage is 2 kVd.c. between input and output, input and case on models with input code A, B, 24, 48.

On models with input code C,110, 220 and D the insulation voltage is 2.5 kVa.c between input and output, input and case (Option E1). The output to case isolation is 2 kVd.c. on all models. Option E1 and E2 can increase this isolation.

If the isolation test equipment cannot supply the AC current, you can perform a DC isolation test with 4000 Vd.c ($2500\text{ V} \times \sqrt{2} \times 1.1 \approx 4000\text{ Vd.c}$ where 1.1 = safety factor).

9.1 DC isolation test output to case

1. Disconnect all cables from the converter.
2. Check *Figure 11* or *Figure 12* to include the alarm relay option. The relay outputs are insulated from output/input/case.
3. Connect the input terminals of the converter to case.
4. Connect the output terminals together.

5. Connect your isolation tester between output and case.
6. Raise the voltage of the isolation tester from 0 to 2000 Vd.c. (With option E2 0 to 4000 Vd.c.) Check that the leakage current does not exceed 5 μ A. The voltage should not be applied for more than a few seconds or the Y-capacitors might be damaged.
7. **Turn off the isolation tester and discharge the test voltage with a 10 M Ω resistor between output and case.**

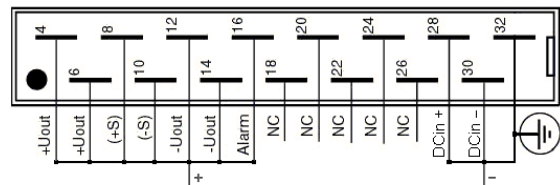

Figure 11. Output to case isolation voltage test.

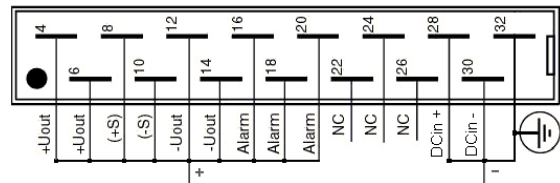

Figure 12. Output to case with relay alarm isolation voltage test.

9.2 AC isolation test output to case, option E2

Beware of the rather high capacitive earth currents (about 100 mA) that will occur during this test.

1. Disconnect all cables from the converter.
2. Check *Figure 11* or *Figure 12* to include the alarm relay option. The relay outputs are insulated from output/input/case.
3. Connect the input terminals of the converter to case.
4. Connect the output terminals together.
5. Connect your isolation tester between output and case.
6. Raise the voltage of the isolation tester from 0 to 2500 Va.c. The voltage should not be applied for more than one (1) minute or the Y-capacitors might be damaged.
7. **Turn off the isolation tester and discharge the test voltage with a 10 M Ω resistor between output and case.**



Warning!

An isolation test shall only be performed by personnel aware of the dangers and hazards of the test.

9.3 DC isolation test input to output and input to case

1. Disconnect all cables from the converter.
2. Check *Figure 13* or *Figure 14* to include the alarm relay option. The relay outputs are insulated from output/input/case.
3. Connect the output terminals of the converter to case.
4. Connect the input terminals together.
5. Connect your isolation tester between input and case.
6. Raise the voltage of the isolation tester from 0 to 2000 Vd.c. (With option E1 or input code C, 110, D raise from 0 to 4000 Vd.c.). Check that the leakage current does not exceed 5 μ A. The voltage should not be applied for more than a few seconds or the Y-capacitors might be damaged.
7. **Turn off the isolation tester and discharge the test voltage with a 10 M Ω resistor between input and case.**

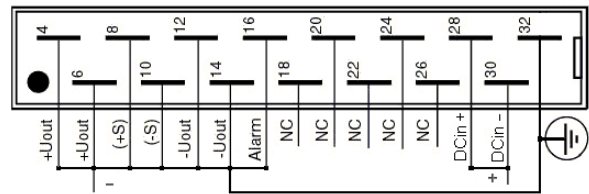

Figure 13. Input to output and input to case isolation voltage test.

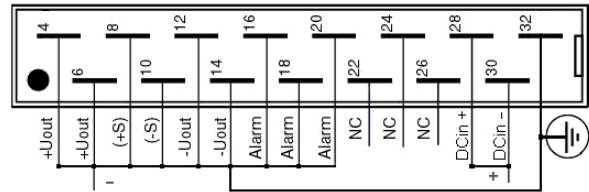

Figure 14. Input to output and input to case with relay isolation voltage test.

9.4 AC isolation test input to output and input to case (Option E1)

Beware of the rather high capacitive earth currents (about 100 mA) that will occur during this test.

1. Disconnect all cables from the converter.
2. Check *Figure 13* or *Figure 14* to include the alarm relay option. The relay outputs are insulated from output/input/case.
3. Connect the output terminals of the converter to case.
4. Connect the input terminals together.
5. Connect your isolation tester between input and case.
6. Raise the voltage of the isolation tester from 0 to 2500Va.c. The voltage should not be applied for more than one (1) minute or the Y-capacitors might be damaged.
7. **Turn off the isolation tester and discharge the test voltage with a 10 M Ω resistor between input and case.**

10 Trouble shooting

10.1 There is no output voltage

1. Check that the input fuse is not broken.
2. Check that the input voltage polarity is correct.
3. Check that the input voltage is within the specified limits.
4. The converter may be in current limit due to excessive output current or an external short-circuit on the output.
 - Measure the output voltage. If shows > 0.5 V the thyristor OVP, *see section 7.2*, might have triggered.
 - Disconnect the input by removing the fuse.
 - Disconnect the load.
 - Connect input fuse again and measure the output voltage. If the converter now starts the load was too heavy or there was a short-circuit.
 - If there is an external short-circuit, remove it.
 - If the load is too large decrease the load or consult your Polyamp dealer.
5. The unit is broken. Contact your Polyamp dealer.

10.2 The input fuse blows when the input is connected

1. Check that the input voltage polarity is correct.
2. Check that the input fuse is of time delay type and with correct current rating. See *Table 1*.
3. The unit is broken. Contact your Polyamp dealer.

10.3 The converter starts and stops repeatedly

All models have an over/under voltage protection which shuts down the converter if the input voltage is not within specified limits:

1. The cables to the converter input may be under-sized, causing too high voltage drop in the supply cables.
2. Your supply does not have enough current capacity so the input voltage to the converter drops below specified limit.

10.4 Fault report

We do not recommend you to repair a faulty unit. All unit opened by customer will not be repaired under warranty.

Please use our RMA system from our webpage www.polyamp.com

Warranty

All Polyamp DC/DC converters are warranted against defective material and workmanship. This warranty is valid for 24 months from the date of delivery. We will repair or replace products which prove to be defective during the warranty period. The warranty is valid only if the converter is used within specification.

Please describe the conditions when the fault occurred and please return a faulty converter to:

Your local distributor or:

SWITCH CRAFT S.A.
Bel Air 63
CH-2300 La Chaux-de-Fonds
Switzerland

Tel: +41 32 9678800 Fax: +41 32 9678809
e-mail: info@switchcraft.ch

Latest version of this manual
www.polyamp.com