

SM6000-Series

- SM 15-400
- SM 30-200
- SM 45-140
- SM 60-100
- SM 70-90
- SM 120-50
- SM 300-20

Safety Instructions

Caution.

The following safety precaution must be observed during all phases of operation, service and repair of this equipment. Failure to comply with the safety precautions or warnings in this document violates safety standards of design, manufacture and intended use of this equipment and may impair the built-in protections within.

Delta Elektronika shall not be liable for user's failure to comply with these requirements.

Installation category.

The Delta Elektronika power supplies have been evaluated to installation category II. (Over voltage category II)

Grounding

This product is a safety Class 1 instrument. To minimize shock hazard, the instrument chassis must be connected to the AC Power Supply mains through a three or four conductor power cable for resp. a single or three phase unit, with the ground wire firmly connected to an electrical ground (safety ground) at the power outlet.

For instruments designed to be hard-wired to supply mains, the protective earth terminal must be connected to the safety electrical ground before another connection is made. Any interruption of the protective ground conductor, or disconnection of the protective earth terminal will cause a potential shock hazard that might cause personal injury.

Fuses

Fuses must be changed by authorized Delta Elektronika service personnel only, for continued protection against risk of fire.

Input Ratings

Do not use an AC Supply which exceeds the input voltage and frequency rating of this instrument. The input voltage and frequency rating of the Delta Elektronika power supply series are stated in the accompanying datasheet.

Live circuits

Operating personnel must not remove the instrument cover. No internal adjustment or component replacement is allowed by non Delta Elektronika qualified personnel. Never replace components with the power cable connected. To avoid injuries, always disconnect power, discharge circuits and remove external voltage sources before touching components.

Parts Substitutions & modifications

Parts substitutions and modifications are allowed by authorized Delta Elektronika service personnel only. For repairs or modifications the unit must be returned to a Delta Elektronika service facility.

Safety instructions

Environmental Conditions

The Delta Elektronika power supplies safety approval applies to the following operating conditions:

- Indoor use
- Ambient temperature : -20 to 50 °C
- Maximum relative humidity : 95%, non condensing, up to 40 °C
: 75%, non condensing, up to 50 °C
- Altitude: up to 2000m
- Pollution degree 2



Caution risk of electrical Shock



Instruction manual symbol. The instrument will be marked with this symbol when it is necessary for the user to refer to the instruction manual



Protective ground conductor terminal



Off (supply)



On (Supply)

DESCRIPTIONS

1) OUTPUT

The SM15-400, SM30-200, SM45-140, SM60-100, SM70-90, SM120-50 and SM300-20 can either be used as a constant voltage source with current limiting or as a constant current source with voltage limiting.

The change of mode occurs sharply at the crossing of the voltage and current settings. Fig. 3 - 1 shows the output ranges.

◦ DISPLAY CV/CC SETTING FUNCTION

The setting of the voltage and current control (also when programmed) can be observed on the front panel meters by pressing the Display CV/CC Setting button. This allows the current limit to be set when operating in the CV mode without shorting the output terminals, and the voltage limit to be set when operating in the CC mode without opening the load leads.

◦ OVERLOAD PROTECTION

The power supply is fully protected against all overload conditions, including short circuit.

2) INPUT VOLTAGE

The power supplies have a wide input voltage range.

- The unit needs a 3 phase input voltage, but **no neutral connection** is required.
- The unit only operates on three phases. In case of **Phase Loss**, the ACF-status (AC Fail) will be high, the ACF-LED will light and the output shuts down after a few seconds.

3) INPUT CURRENT

The unit has active power factor correction (PFC). The input current will therefore almost be a sine wave. This means that the RMS-value and the harmonic distortion of the input current will be relatively low.

The peak inrush current is electronically limited. Switching on and off repeatedly will not result in excessive currents like with NTC circuits.

4) STANDBY INPUT POWER

The unit consumes very little power when in standby. This makes it possible to leave the input power on when the output is disabled using the Output On/Off function (push button on front panel) or the Remote ShutDown input (pin 5 on connector CON E on the rear panel).

5) EFFICIENCY

The efficiency is very high and constant over a wide output current range. High efficiency means low power loss and low heat generation.

6) CV REGULATION

The CV-load regulation should be measured directly on the output terminals because a few cm of cable can have a voltage drop of several mV (at high current!).

7) CC REGULATION

For accurate CC-load regulation, do not use external voltage sensing. A voltage between S- and minus output will create an error of about 0.04 % per volt.

A voltage between S+ and + is not critical. The CC-stability is also affected by external voltage sensing.

Note: when the unit operates in CC-mode, the **DCF-LED** will be on. When the unit is in CC-mode most of the time, this LED can be disabled with dipswitch 3 on SW1 (rear side).

8) RIPPLE & NOISE

The output ripple is very low with almost no spikes. The ripple voltage has to be measured directly on the output terminals using a probe with very short connections (to avoid pick up of magnetic fields). See fig. 3 - 2 and fig. 3 - 3.

At low temperatures like -20°C the ripple increases. By using high quality electrolytic capacitors the increase is relatively low.

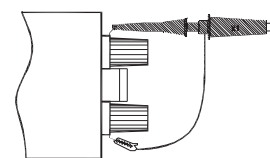
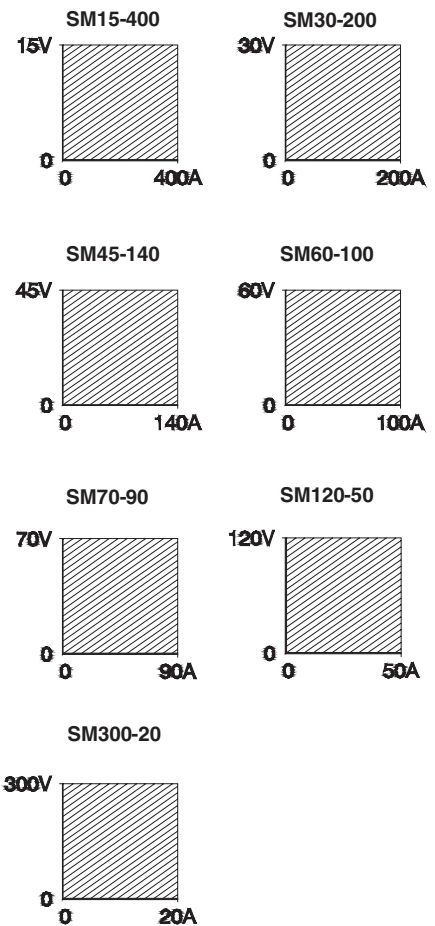

fig. 3 - 2
measuring ripple voltage
WRONG !

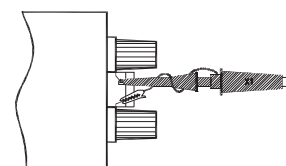

fig. 3 - 3
measuring ripple voltage
RIGHT !

9) **ANALOG PROGRAMMING**

The output voltage and current can be programmed by an external analog voltage. This programming is very accurate and linear. The levels are all standardised on 5V.

The inputs have a protection circuit formed by a series resistor and a parallel zener, see fig. 3 - 4. The capacitor limits the speed to a safe value. Note that the analog inputs (and outputs) are **not floating, but the common is connected to the negative output terminal**. Wrong connection of \emptyset can cause earth loops which can trip the fuse. After removing the fault, the fuse will reset (PTC-fuse). For isolated programming see paragraph 10).

10) **ISOLATED ANALOG PROGRAMMING**

To prevent earth loops which can cause programming errors, use an isolated programming source. If this is not possible, use the optional **ISO AMP CARD** (δ -product) which can be built inside the unit. With the ISO AMP CARD it is not possible to have earth loops between the unit and the programming source.

11) **IEEE 488 / RS232 PROGRAMMING**

Both the Delta Elektronika **PSC488 INT** and the **PSC232 INT** controllers can be built inside the unit.

Voltage and current can easily be programmed and read back. Also all the status outputs can be read by the computer.

12) **MONITORING OUTPUTS**

The monitor outputs give a voltage 0 - 5 V proportional to the output current or voltage. The output current can easily be measured using the I-monitor, see fig. 3 - 6. The monitor outputs are buffered with op-amp's and protected with series resistors and parallel zeners see fig. 3 - 7. The table in fig. 3 - 5 shows the impedance levels of the monitoring outputs.

For using Imon on a pulsating load, see paragraph 20) of this chapter.

13) **+12V ON PROGRAMMING CONNECTOR**

The +12V on the programming connector can be used to supply external circuits. The output is current limited, but should not be overloaded. The fuse F27_3 on P598 could blow. The fuse F27_3 also protects the internal circuit, in case an external high voltage is applied by accident. Note: this fuse is a special 600V type, always replace with the same type.

14) **STATUS OUTPUTS**

All the status outputs are logic outputs. Logic "0" means the output is 0 V, logic "1" means the output is 5 V ($R_o = 500 \text{ Ohm}$). This makes it possible to drive directly: an opto-coupler, a TTL gate or a CMOS gate.

The Limit Status or **LIM-status** is "1" in case the output voltage or current reaches the limit setting. Which limit circuit is active can be seen on the front panel LED's or by combining the CC-status output.

The Over Temperature Status or **OT status** is "1" in case of an over temperature, the OT LED will be on and the output shuts down. As a pre-warning the OT LED starts to blink when the unit runs hot but the situation of over temperature is not reached yet. The status will still be low when the LED is blinking.

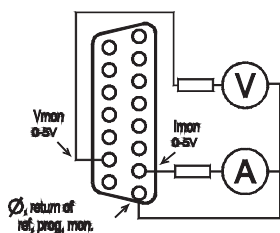

fig. 3 - 6
external meters
using monitor outputs

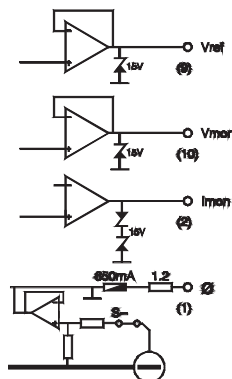

fig. 3 - 7
buffered monitor outputs
(internal circuit)

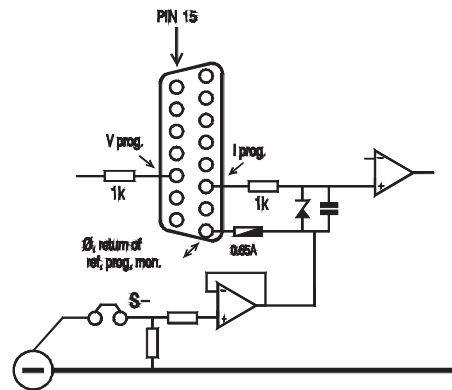

fig. 3 - 4
programming inputs (internal circuit)

\emptyset of ref. prog. mon.	1	9	Ref. 5.1V
I monitor	2	10	V monitor
I program	3	11	V program
CC status	4	12	OT status
RSD	5	13	LIM status
PSOL	6	14	DCF status
+12V	7	15	ACF status
\emptyset of status and +12V	8		

pin	Description, see par.12)...17) for details
1	\emptyset , return of reference, prog. inputs and monitor outputs ($R_o = 1.2 \text{ Ohm}$).
2	current monitor output 0 - 5V ($R_o = 1.2 \text{ Ohm}$, $I_o \text{ max} = 4 \text{ mA}$)
3	current programming input (0 - 5V), $R_i = 8 \text{ MOhm}$
4	CC status output, logic 1 = CC mode (5 V / 500 Ohm)
5	Remote shutdown (4 - 12 V), $R_i = 5 \text{ kOhm}$
6	PSOL status output, logic 1 = PSOL (5 V / 500 Ohm)
7	+12 V output ($R_o = 3 \text{ Ohm}$, $I_o \text{ max} = 0.2 \text{ A}$)
8	\emptyset , return of status outputs, +12 V and remote shutdown
9	reference voltage 5.1 V ($R_o = 1.2 \text{ Ohm}$, $I_o \text{ max} = 4 \text{ mA}$)
10	voltage monitor output 0 - 5V $R_o = 1.2 \text{ Ohm}$, $I_o \text{ max} = 4 \text{ mA}$)
11	voltage programming input (0 - 5V) $R_i = 8 \text{ MOhm}$
12	OT - status output, logic 1 = OT (5 V / 500 Ohm)
13	LIM - status output, logic 1 = LIM (5 V / 500 Ohm)
14	DCF - status output, logic 1 = DCF (5 V / 10 mA)
15	ACF - status output, logic 1 = ACF (5 V / 500 Ohm)

Fig. 3 - 5
connections ANALOG PROG. CONNECTOR



fig. 3 - 9 location of output terminals and analog prog. connector on rear panel

CON A	Interlock Connector
CON B	Master connector for Master / Slave operation (output)
CON C	Slave connector for Master / Slave operation (input)
CON D	Relay Outputs, contacts 1 - 6
CON E	Analog Programming Connector
CON F	PSC 232 INT, from PC or previous PSC (optional)
CON G	PSC 232 INT, to next PSC (optional)
CON H	PSC 488 INT (optional) or ISO AMP CARD (optional)
SW 1	Various settings, see paragraph 16)
SW 2	Settings for PSC 488 INT (optional)

fig. 3 - 8 connectors and switches on the rear panel

The Current Control Status or **CC-status** output is "1" when the unit is in CC-mode.

The Power Sink OverLoad Status or **PSOL-status** output is "1" when the optional Power Sink is overloaded or overheated.

The AC-Fail Status or **ACF-status** output is "1" in case of Phase Loss or when the input voltage is below 340V.

The DC-Fail Status or **DCF-status** output is "1" when the output voltage is either 5% below or above the set point.

When the unit is in CC-mode, DCF will always be "1", see paragraph 7) of this chapter.

15) STATUS RELAY OUTPUTS

The power supply has 2 status relay outputs, with each a change-over contact. They are connected to connector CON D. The pins 1,2,3 are connected to the DCF-relay and pins 4,5,6 to the ACF-relay. See fig. 2 - 10.

16) FUNCTION SWITCHES ON SW1

In the following table the functions of the dipswitches 1-4 of switch SW1 (rear side) are explained:

Switch no.	ON position	OFF position	Default Setting
SW 1 - 1	Programming via 15pole connector CON E (analog).	Optional programming with e.g. PSC232, PSC488, ISO AMP CARD	ON (up)
SW 1 - 2	'Output On' after mains on	'Output Off' after mains on	OFF (down)
SW 1 - 3	DCF LED enabled	DCF LED disabled (DCF status and DCF relay are still enabled)	ON (up)
SW 1 - 4	Parallel Master / Slave operation	Series Master / Slave operation	ON (up)

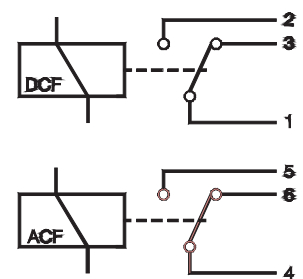

fig. 3 - 10
Status relay outputs on CON D.
This situation gives the relay positions during fault condition.

17) **REMOTE SHUTDOWN (RSD)**

A voltage of +4 V...+12 V on the Remote ShutDown input on the programming connector CON E will switch off the output of the unit. It is also possible to use a relay contact or a switch to shut the unit down, see fig. 3-11. In standby mode the power supply consumes very little power.

18) **INTERLOCK**

The Interlock connector (CON A, rear panel) has 2 inputs which have to be connected together to turn on the output of the unit. As soon as the link between the 2 inputs of the Interlock connector is disrupted, the output of the unit shuts down. It can be used in combination with a cabinet door contact (safety precaution) or as an emergency break to stop a motor which is powered by the unit. In case the link is disrupted the RSD LED will light. In contrast with Remote ShutDown, also the DCF LED will be on, the DCF status will be high and the relay contact will change. Once the inputs are connected again, the output will be on. No voltage may be applied to the pins in the Interlock connector.

19) **PROGRAMMING SPEED**

The rise and fall time is measured with a step waveform at the CV prog. input. Programming from a low to a high output voltage is nearly load independent, but programming down to a low voltage takes more time on lighter loads. This is caused by the output capacitors, which can only be discharged by the load because the power supply cannot sink current. When having a unit with a **fast programming option**, the rise and fall time is 5 to 25 times faster (see datasheet). The programming source must be floating or otherwise an ISO AMP CARD must be used. When using fast programming it is generally not recommended to use remote sensing or serial / parallel operation. Consult factory for advice. Also the output ripple is higher.

20) **PULSATING LOAD**

To avoid overheating the output capacitors, the AC component of the load current should be limited. See fig. 3 - 12. One method of decreasing the AC current through the output capacitor is by using a large external electrolytic capacitor in parallel with the load. Care must be taken so that the capacitor in combination with the lead inductance will not form a series resonant circuit! When using **remote sensing** on a pulsating load (for instance a DC-motor), use a capacitor in series with a resistor over the load. See fig. 3 - 13. Like this the AC-component caused by the pulsating of the load is filtered. **Note:** in case of a **pulsating load**, the I monitor voltage will not exactly match the output current. This is mainly caused by the current through the output capacitors. Remote sensing will worsen this effect.

21) **INSULATION**

For safety the insulation of the separating components (transformers) between input and output is tested at 3750 Vrms during 1 minute. This is tested before assembly. **Warning!** The 3750 Vrms cannot be tested afterwards on the assembled unit because the insulation between the components on the input side to the case (like the bridge rectifier) is specified at 2500 Vrms. Since the insulation output - case is low (only 600 VDC) the insulation of the primary components to case will break down when 3750 Vrms is applied between input and output (2500 Vrms + 600 VDC < 3750 Vrms). See also fig. 3 - 14. **Note:** when testing the insulation, take care to charge and discharge the capacitors between input - case and output - case slowly (e.g. in one second). This to prevent high peak currents, which could destroy the power supply. Make sure to discharge the capacitors completely before using it again.

22) **RFI SUPPRESSION**

Both the input and output have RFI filters, resulting in very low

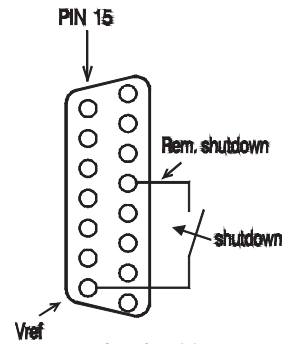

fig. 3 - 11
Remote ShutDown using a relay contact

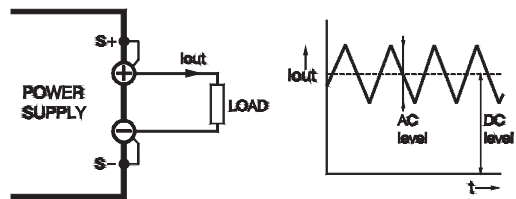

fig. 3 - 12
pulsating load current

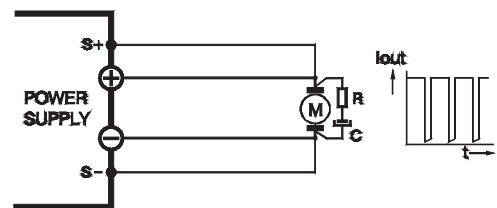

fig. 3 - 13
remote sensing on a pulsating load

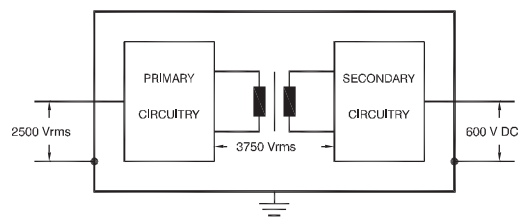

fig. 3 - 14
insulation test voltages

conducted RFI to the line and load. Due to the output filter the output voltage is very clean, having almost no spikes.

23) OPERATING TEMP

At full power the operating temperature range is -20 to $+50$ °C. From 50 to 60 °C the output current has to be derated linearly to 75% at 60 °C. See fig. 3 - 15. These temperatures hold for normal use, i.e. the ventilation openings on the left and right side must be free.

24) THERMAL PROTECTION

A thermal switch shuts down the output in case of insufficient cooling. The OT status will be high. After cooling down the unit will start working again.

The OT-LED on the front panel will be on and the OT-status signal will be "1" in case of a tripped thermal protection.

As a pre-warning the OT-LED blinks (status will still be low), this will start before the power supply shuts down.

25) HOLD - UP TIME

The hold - up time depends on the load and the output voltage. A lighter load or a lower output voltage results in a longer hold - up time, see fig. 3 - 16.

26) TURN ON DELAY

The output voltage is available 0.2 sec after mains switch on.

27) INRUSH CURRENT

The inrush current is electronically limited to about 20 A. Repeatedly switching on and off does not change the maximum peak current.

Switching on and off at a fast rate can overheat the inrush current limiter. With the result that the unit does not start anymore. After cooling down (mains switched off) it will be OK again.

28) PHASE LOSS

Phase loss means that not all three phases are available. The ACF-status will be high, the ACF LED will light and the output of the unit will shut down after a few seconds.

29) REMOTE SENSING

The voltage at the load can be kept constant by remote sensing. This feature is not recommended for normal use but only when the load voltage is not allowed to vary a few millivolts. Always use a **shielded cable** for sensing.

In order to compensate for the voltage drop across the load leads, the unit will have to supply a higher voltage, see fig. 3 - 17:

$$U_{out} = (\text{voltage drop across each lead}) + (\text{voltage across the load}).$$

The voltage limit reads the voltage directly at the output terminals. To protect the load, the setting for the limit must therefore be increased by the total voltage drop across the load leads.

The voltage display on the frontpanel and the voltage monitor output on CON E are connected to the sense leads and therefore read the voltage across the load and **not** the voltage on the output terminals.

The sense leads are protected against **accidental interruption**. The maximum voltage between the output terminals and the sense inputs is limited at 2.5 V.

For sensing on a **pulsating load** see par.20) of this chapter.

30) SERIES OPERATION

Series operation is allowed up to 600 V total voltage. The power supplies can be connected in series without special precautions.

For easier control, Master / Slave operation is recommended (fig. 3- 18). By using the *Master / Slave - Series* feature a **dual tracking** power supply can be made with one unit as master and one as slave.

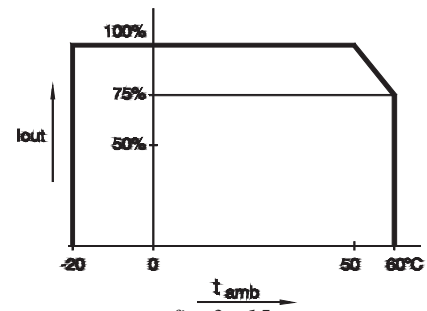

fig. 3 - 15

operating temperature ranges

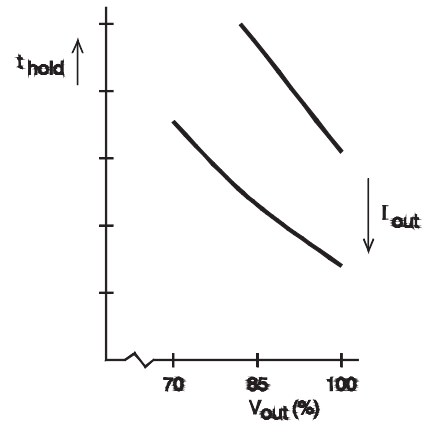
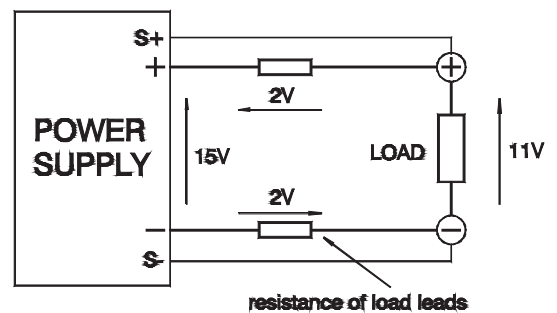

fig. 3 - 16

hold-up time vs Vout with Iout as a parameter



resistance of load leads

fig. 3 - 17

remote sensing, voltage drop in load leads subtracts from max. output

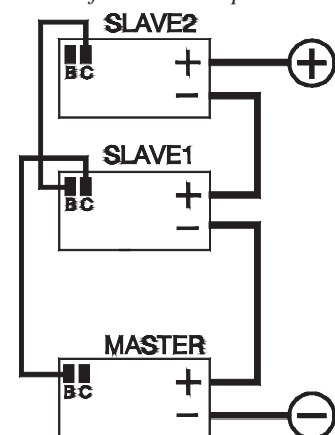

fig. 3 - 18

Master / Slave series operation

31) **PARALLEL OPERATION**

Paralleling of the units has no limitations. The power supplies can be connected in parallel without special precautions.
 For easier control, Master / Slave operation is recommended (see fig. 3- 18 and fig. 3 - 19).

Note: Master / Slave parallel operation is not recommended for more than 3 units, consult factory for a solution with more than 3 units.

- **Parallel operation of fast programming versions:**
 Master / Slave operation is not recommended.
 Normal parallel operation can give problems, each combination has to be tested first, in combination with the load !

32) **MASTER / SLAVE OPERATION**

The Master / Slave feature makes it possible to use the power supplies as building blocks to form one large unit, see fig. 3 - 19.

Mixed parallel - series operation is also possible (fig. 3 - 20), to a maximum of 600V.

The resulting combination of units behaves like one power supply and can be manually controlled or programmed on the master. Fig. 3 - 21 shows a computer controlled M / S parallel combination.

Connect the different units with standard RJ45 cables, see fig 3 - 22, using CON B and CON C on the rear side. With dipswitch 4 of switch SW1 the Parallel or Series mode can be selected.

The slaves will follow the master. The result is true **current or voltage sharing** in the parallel or series mode respectively.

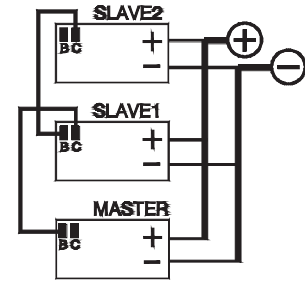

fig. 3 - 19
 Master / Slave Parallel Operation

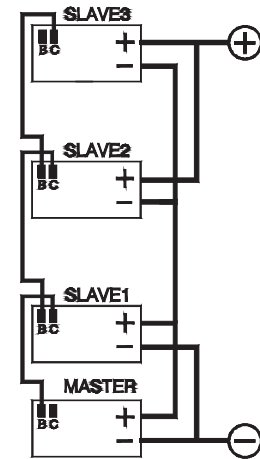

fig. 3 - 20
 Master / Slave Mixed Series-Parallel

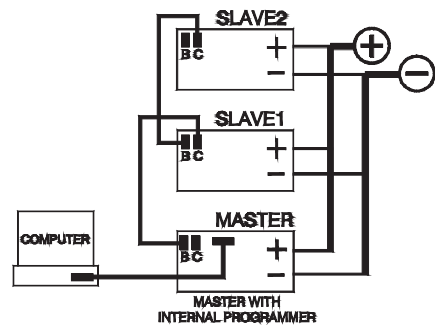

fig. 3 - 21
 the Master / Slave combination can also be programmed with the interfaces PSC488 INT or the PSC232 INT

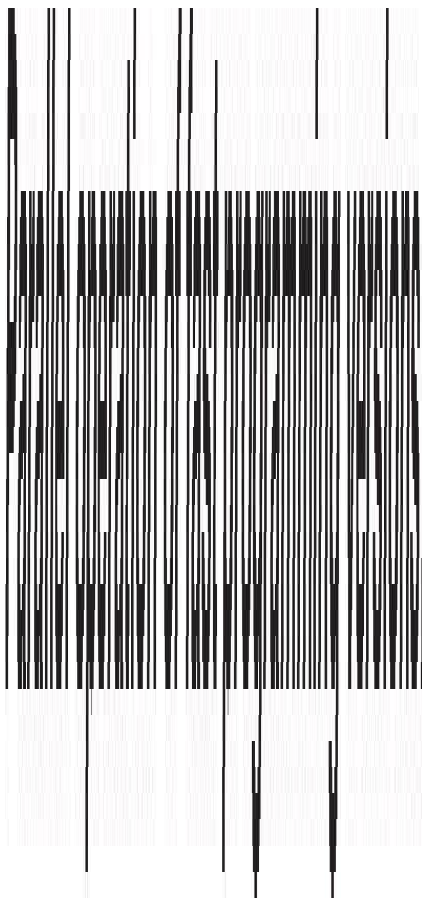

Fig 3 - 22
 Use standard UTP cables (RJ45) for Master / Slave operation

33) **VOLTAGE AND CURRENT LIMIT**

The Voltage Limit will protect your circuit from unwanted high voltages. A high output voltage could be caused by accidental interruption of leads, accidentally turning up the voltage potmeter, a programming error or a defect in the power supply. The Voltage Limit circuit uses a separate voltage divider connected directly to the output terminals.

The Current Limit protects your circuit from unwanted high currents.

The Voltage and Current Limits maintain the output to a safe preset value. They do not trip, so no resetting is needed after a fault. It can be very handy to have hardware limits when the power supply is programmed.

The limits can easily be set by pressing the DISPLAY LIMITS button and adjusting the potentiometers with a screwdriver. The LED's next to the potmeters indicate the activity of each limit, also the LIM-status output will be "1".

34) **POTENTIOMETERS**

- Standard: - CV and CC potentiometers with knobs at front panel, Voltage Limit and Current Limit potentiometers with screwdriver adjustment at the front panel.
- Option P001: - Screwdriver adjustment for CV, CC, Voltage Limit and Current Limit at the front panel, fig. 3 - 23.

35) **COOLING**

Two low noise blowers cool the unit. The speed of the fans depend on the temperature of the internal heatsink. Normally at 50 °C ambient and full load the fan will not work at full speed.

A special feature is that the fans blow through a tunnel where the heatsinks are situated, the delicate control circuitry is separated and will not be in the airflow path, see fig. 3 - 24.

Because the air enters at the left and exits at the right side it is possible to stack the power supplies, no distance between the units is required. Only the ventilation openings at the left and right side should be free.

For long life the temperature of the air entering on the left side, should be below 35 °C under normal conditions. Under extreme conditions it should be below 50 °C.

Note: The control circuit makes the fan start in a pulsating mode, during which period it can produce a high pitched sound. This is normal.

36) **DIMENSIONS**

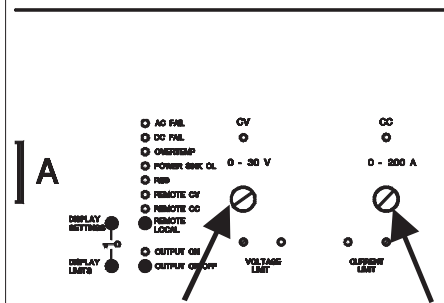
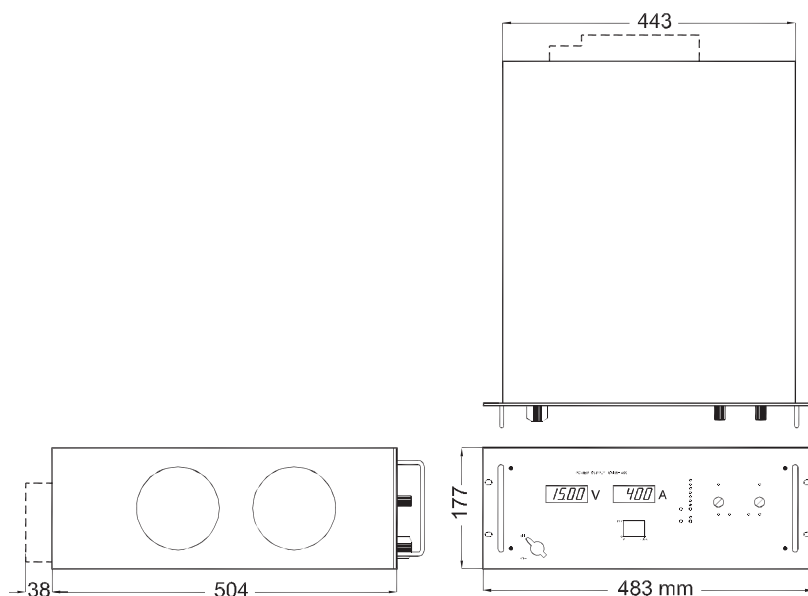

fig. 3 - 23
screwdriver adjustment at front panel

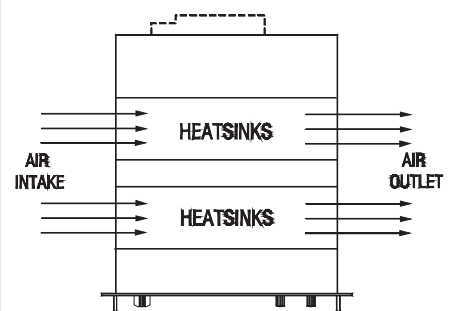

fig. 3 - 24
the two fans blow through the tunnels,
where the heatsinks are situated

OPERATING MANUAL

1) OPERATING THE UNIT FOR THE FIRST TIME

- Check there is no condensation on the unit. If there is, allow some time to dry.
- Check there is a link between + and S+ and between – and S– on the SENSE BLOCK (on rear panel).
- Check there is a link between the inputs of the Interlock (CON A, rear panel).
- Set the CV and CC potentiometers to minimum (fully anti clock-wise).
- For cable diameters and mounting torque see tabel 3 -1.
- With **high output current** make sure to use low resistive connections between the power supply and the load:
 - Mount the cable lugs *directly* on the tinned output strips followed by a washer, a split washer and a nut, see fig. 4 - 1. Always in this order!
 - Never place washers between the lugs and the strips because this can result in excessive heat!
 - Only use nuts and washers supplied with the unit.
- Switch on unit.
- Disable the Keylock function, see next paragraph.
- Check the unit is not in Remote CV or Remote CC (LED's for this function should be off). Press the REMOTE/LOCAL button until both LED's are off.
- Turn on the output pressing the OUTPUT ON/OFF button.
- Turn both the CV and CC potentiometer a few turns clock wise. A voltage should now be present on the output.
- By pressing the DISPLAY CV/CC SETTING button the meters will show the setting of the CV and CC potentiometer.
- By pressing the DISPLAY LIMITS button the voltmeter will show the setting of the CV-limit and the CC-limit potentiometer.
- Check that the cooling of the unit is not obstructed.

2) KEYLOCK

- If the function KEYLOCK is activated, it is no longer possible to operate the REMOTE/LOCAL button and the OUTPUT ON/OFF button. This function can be useful to protect the output from accidental shut down. The function KEYLOCK does not influence the operating of the potmeters.
- **Activate Keylock:**
Pressing the buttons DISPLAY SETTINGS and DISPLAY LIMITS at the same time for more than 3 seconds, activates the function KEYLOCK. The moment this function is activated, the LED's for REMOTE CV / CC and for OUTPUT ON will blink a few times.
- **Disable Keylock:**
Pressing the same buttons again for 3 seconds, disables the Keylock function. The LED's for REMOTE CV / CC and for OUTPUT ON will blink again to indicate the new setting.

3) ANALOG PROGRAMMING

- Set dipswitch 1 of SW1 in position ON to select CON E for programming.
- Disable Keylock.
- Set the unit in REMOTE CV for voltage programming and/or in REMOTE CC for current programming. Use the REMOTE/LOCAL button and push this button several times until the right setting is activated. Note that pushing the REMOTE/LOCAL button will shut down the output to avoid accidental damage to the load.
- Turn the output on again with the OUTPUT ON/OFF button.
- Connect the programming voltage source(s) (0 - 5 V) to the analog programming connector CON E on the rear panel. See fig. 4 - 2 and fig. 4 - 3. Always use a **shielded cable** (max. 30 meter) for programming.
- If only the voltage is programmed, the max. current can still be set with the CC potentiometer and vice versa. If this is not desirable the unit can be ordered with Option P001 in order to have a fixed setting for the CV or the CC potiotiometer on the front panel.



fig. 4 - 1
low resistive cable connection by mounting the cables directly on the tinned output strips

Unit	SM 15-400	SM 30-200	SM 45-140	SM 60-100	SM 70-90	SM 120-50	SM 300-20
Input cables [mm2]	2.5	2.5	2.5	2.5	2.5	2.5	2.5
Torque [Nm]	0.6	0.6	0.6	0.6	0.6	0.6	0.6
Output cables [mm2]	120	50	25	16	16	6	4
Bolts	M12	M10	M10	M10	M10	M8	M8
Torque [Nm]	80	40	40	40	40	20	20

tabel 3 - 1
Cable diameters and torque

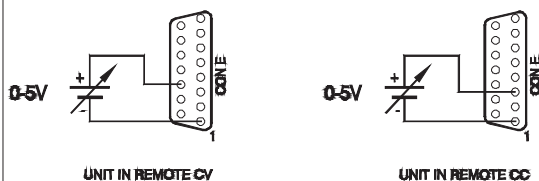

fig. 4 - 2
programming by voltage:
left voltage -, right current programming

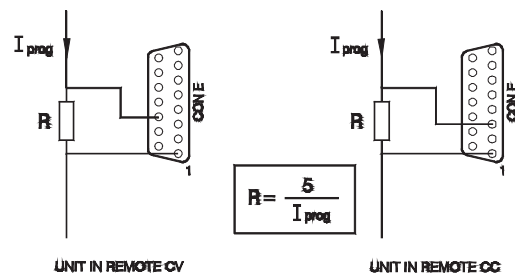

fig. 4 - 3
programming by current
left voltage -, right current programming

- To avoid hum or noise, the programming cable may have to be twisted in some cases.
- To program the unit by current instead of voltage, simply use a parallel resistor as a current to voltage converter.
- Pressing the DISPLAY SETTINGS button will show the programmed values for CV and CC.
- **CAUTION:** The analog inputs are not isolated from the output. The \emptyset of the prog. input (pin 1) is internally connected to the S-, the S- is connected to the negative output. To protect the internal wiring a 650 mA self-resetting fuse is connected in series (F27_1 on P598). To avoid earth loops, use an isolated programming source. If this is not possible, see paragraph 4) for using the optional **ISO AMP CARD**.

4) ANALOG PROGRAMMING WITH ISO AMP CARD

- For programming via the **ISO AMP CARD**, set dipswitch 1 on SW1 in the position OFF.
- When the ISO AMP CARD is built inside the unit, CON E has been removed. Use CON H instead. The pinning of CON H is equal to the pinning of CON E except pin 6 (PSOL), pin 7 (+12V) and pin 9 (Vref) are not available.
- For further operating instructions, see previous paragraph.

5) IEEE 488 / RS232 PROGRAMMING

- Set dipswitch 1 on SW1 in position OFF for programming with the **PSC488 INT** using CON H or programming with the **PSC232 INT** using CON F and G. With dipswitch 1 in this position, the signals Vprog (pin 11) and Iprog (pin 3) are disabled on CON E. All the other signals can still be used.
- Set the unit in REMOTE CV for voltage programming and/or in REMOTE CC for current programming using the SCPI commands (see manual PSC) or using the REMOTE/LOCAL button on the unit. Push this button several times until the right setting is activated. Setting the unit in REMOTE or LOCAL will cause the output to shut down to avoid accidental damage to the load. Turn it on again using the SCPI command or with the OUTPUT ON/OFF button.
- Set dipswitch 1 on SW1 in position ON to enable CON E again for analog programming. In this position voltage and current programming on CON F and H is disabled. The other functions and signals can still be programmed and read back.

6) MONITORING OUTPUTS

- The 5 V level is compatible with most interfaces.
- The monitoring outputs can drive a meter directly, fig. 4 - 4.

7) STATUS OUTPUTS

- The status outputs have a separate \emptyset connection (pin 8) to avoid unwanted offsets in the programming. This pin is protected with a 650 mA self resetting fuse (F27_2 on P598).

8) REMOTE SENSING

- Remove the links on the SENSE BLOCK (on rear panel) and connect sense leads (thin **shielded** measuring wires) to S+ and S-. See fig 4 - 5 and fig. 4 - 6.
- With remote sensing the voltage on the load can be kept constant. The voltage drop in the load leads will be compensated. This feature is not recommended for normal use, because it can easily give problems.
- Max. 2 V per load lead can be compensated. Note that the voltage drop in the leads decreases the max. output voltage rating. In fig. 4 - 7 it can be seen that on a 15V power supply only 11V will be available on the load when 2x 2V compensation is used.
- In order to prevent interference it is advisable to twist the sense leads. To minimise the inductance in the load leads keep the leads close to each other. The inductance of the load leads could give a problem with pulsating loads. In this case a large electrolytic capacitor (Cd) in series with a damping resistor (Rd) both in parallel with the load will help, see fig.

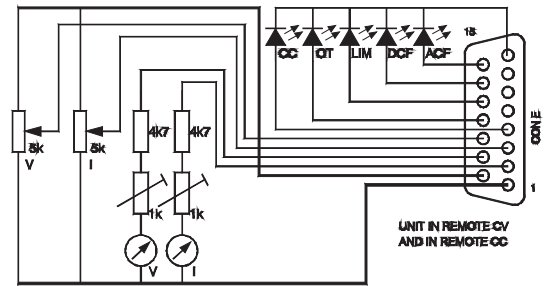

fig. 4 - 4
remote control

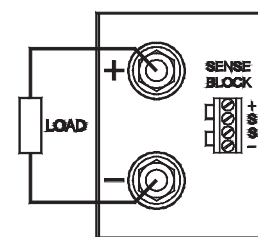

fig. 4 - 5
local sensing

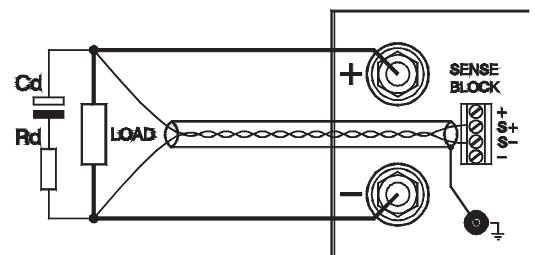

fig. 4 - 6
remote sensing with shielded wires

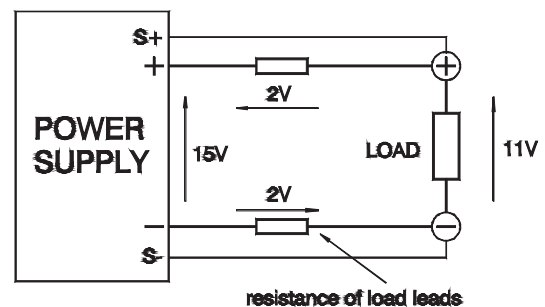

fig. 4 - 7
remote sensing, voltage drop in load leads subtracts from max. output

4 - 6. Check that the capacitor Cd in combination with the load leads and resistor Rd forms a well damped circuit.

- Since the **voltmeter** is internally connected to the sensing terminals, it will automatically indicate the **voltage on the load**. Note that the voltage measured on the load will be lower than on the output terminals.
- The Over Voltage Limit measures the voltage on the output terminals, so the OVL setting should be increased by the total voltage drop in the load leads.

9) **BATTERY CHARGER**

- The CV / CC regulated power supplies are ideal battery chargers. Once the output is set at the correct voltage the battery will charge constantly without overcharging. This can be useful for emergency power systems.
- **Protective measures**
Use a CIRCUIT-BREAKER in series in order to protect the power supply from **accidental reverse connection**, see fig. 4 - . The circuit-breaker should have a DC voltage rating twice the battery voltage. Use the very fast type (Z), a type meant for protecting semiconductors (see table). The unit has a reverse diode in parallel with the output, this diode and the wiring cannot withstand the thousands of amperes supplied by a wrongly connected battery.

10) **REMOTE SHUTDOWN**

- The Remote Shutdown can be operated on CON E by a voltage of +4V...+12V or by a relay contact between Vref and Remote ShutDown (pin 9 and 5), see fig. 4 - 9.
- When the unit is programmed with an optional PSC, a software command can be used for Remote Shutdown.
- In the Remote Shutdown condition, the RSD LED will light. The DCF LED, DCF status and the DCF relay will be off.

Important: If the link from the Interlock connector (CON A) has been removed, the RSD LED will be on, but in this condition also the DCF LED, the DCF status and the DCF relay will be on.

11) **MASTER / SLAVE SERIES OPERATION**

- Connect output terminals and test system in **normal series** operation. Ensure that all (output) power connections are reliable.
- The voltage drop in the connecting leads between the units should be kept < 10 mV.
- Switch off all units. Connect units as shown in fig. 4 - 10. To connect the slaves with the master via CON B and CON C, use standard UTP cables (RJ45). On all units put dipswitch 4 of SW1 in position OFF to set the units in M/S series mode.
- After turning the units on again, the slaves will be in Remote CV mode and the Keylock (see par. 4 - 2) is activated. This is because the unit automatically detects the presence of the RJ45 connector in CON C (if this cable is connected to another unit).
If the RJ45 connector is removed from CON C when the unit is turned on, the output will shutdown to avoid accidental damage.
If the cable is inserted when the unit is turned on, the output shuts down, the unit changes to Remote CV / CC, the Keylock will be activated and the output will turn back on.
If dipswitch 4 of SW1 is operated when the unit is turned on, the output will shutdown to avoid accidental damage.
- The max. number of slaves is only limited by the max. total voltage of 600 V.

Suggested Circuit Breakers for protection power supply			
Model	Type number Circuit Breaker	Brand	Remarks
SM15-400	2x HTI102 B 100	GE	4 poles parallel
SM30-200	HTI102 B 100	GE	2 poles parallel
SM45-140	HTI102 B 100	GE	2 poles parallel extra parallel diode on output needed = OPTION 151
SM60-100	HTI101 B 100	GE	
SM70-90	HTI101 B 100	GE	
SM120-50	S281 UC-Z 50	ABB	extra parallel diode on output needed = OPTION 152
SM300-20	S282 UC-Z 20	ABB	2 poles in series extra parallel diodes on output needed = OPTION 153

circuit breakers for protection.

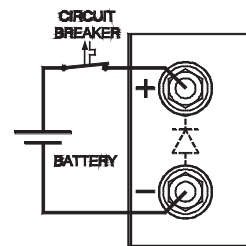

fig. 4 - 8

charging battery with a circuit-breaker in series

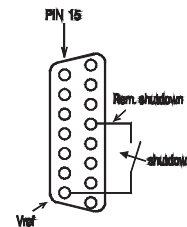

fig. 4 - 9

remote shutdown with switch

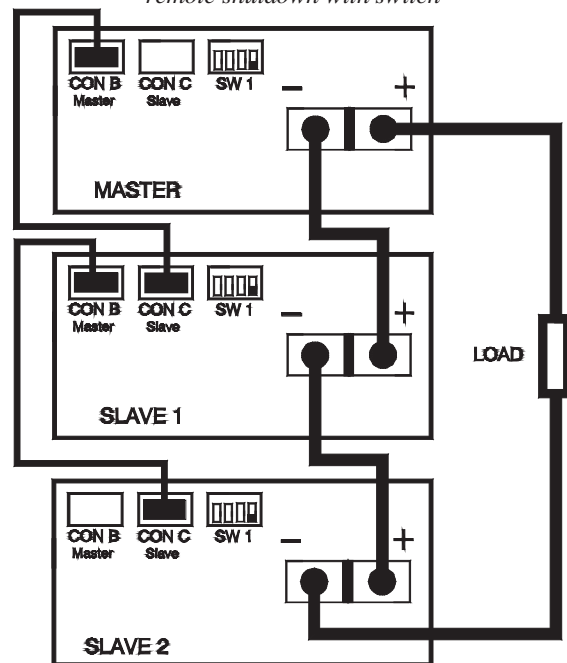

fig. 4 - 10

master slave series connection

12) MASTER / SLAVE PARALLEL OPERATION

- **Note: Master / Slave parallel is not recommended for more than 3 units, consult factory for using more than 3 power supplies in parallel.**
- First connect output terminals and test system in **normal parallel** operation. Ensure that all power connections are reliable.
- Second, switch off all units. To connect the slaves with the master via CON B and CON C, use standard RJ45 connectors according to fig. 4 - 11. On all units put dipswitch 4 of SW1 in position ON to set the units in M/S parallel mode. In this mode the DCF LED, DCF relay and DCF status on the slaves are disabled because the slaves are always in CC mode.
- After turning the units on again, the slaves will be in Remote CC mode and the Keylock (see par. 4 - 2) is activated. This is because the unit automatically detects the presence of the RJ45 connector in CON C (if this cable is connected to another unit).
If the RJ45 connector is removed from CON C when the unit is turned on, the output will shutdown to avoid accidental damage.
If the cable is inserted when the unit is turned on, the output shuts down, the unit changes to Remote CV / CC, the Keylock will be activated and the output will turn back on.
If dipswitch 4 of SW1 is operated when the unit is turned on, the output will shutdown to avoid accidental damage.

- Stack the units to create a minimum distance between the units. Keep the load close to the master. Use copper strips (preferred) or short thick cables to connect the units. Make sure the strips are mounted with a minimum length to keep the voltage drop between a unit and the buss bar below 10 mV. Also keep the strips close to each other to have a low inductance. Not following these instructions can cause instability.
- For operating in parallel mode, **masters** having a serial number (Sn) starting with "228" need a modification. Without this modification instabilities can occur. Note that slaves should NOT be modified. To modify the master, on P597 both the capacitor C26_5 and the resistor R26_36 should be changed according to the values in the table:

unit	C26_5	R26_36
SM15-400, SM30-200, SM45-140	10nF / 50 V	22kOhm
SM60-100, SM70-90	10nF / 50 V	10kOhm
SM120-50, SM300-20	4.7nF / 50 V	15kOhm

- The S- and S+ could be connected to the load if desired, but this is not recommended because of the complexity and possible instability.

13) PARALLEL OPERATION OF FAST PROGRAMMING VERSIONS:

- Master / Slave operation is not recommended.
- Normal parallel operation can give problems, each combination has to be tested first in combination with the load.

14) MASTER / SLAVE MIXED SERIES / PARALLEL OPERATION

- See fig. 4 - 12 for an example of how to connect 2 units in series in parallel with 2 units in series, controlled by 1 master.
- Check the position of dipswitch 4 of SW1 to set the correct M/S mode (series or parallel) for each slave
- Note: A Master / Slave combination can always be programmed, also with the **IEEE488/RS232** controller (**PSC 448 INT / PSC232 INT (both δ -products)**).

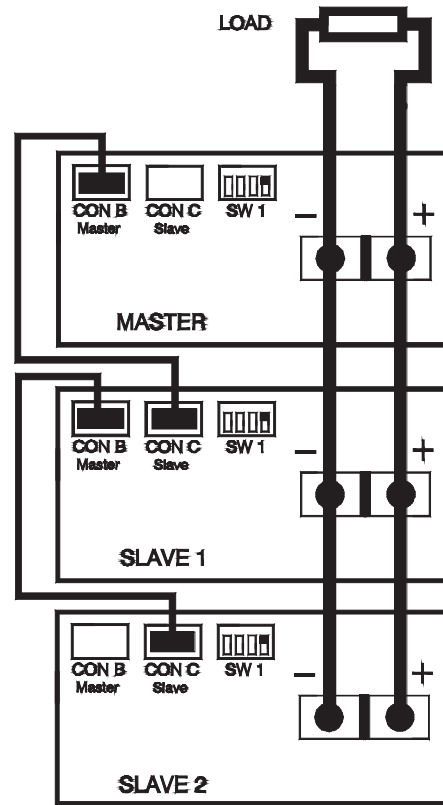

fig. 4 - 11
master slave parallel connections

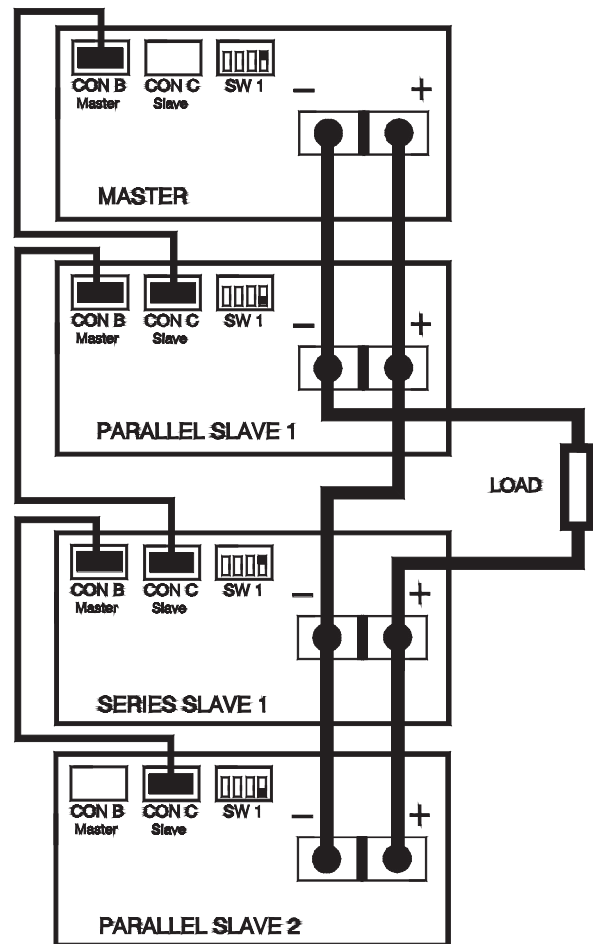

fig. 4 - 12
master slave mixed series - parallel connections

OPERATING AND STORAGE CONDITIONS

1) TEMPERATURE

- The operating temperature range at full load is -20 to $+50$ °C. But this temperature range only holds when the AIR-INTAKE and AIR-OUTLET are unobstructed and the temperature of the AIR-INTAKE is not higher than $+50$ °C.
- **Please note: a lower temperature extends the life of the power supply.**
- When the power supply is **mounted in a cabinet** please note that the temperature of the AIR-INTAKE should be kept low and avoid a short circuit in the airflow i.e. the hot air leaving the AIR-OUTLET entering the AIR-INTAKE again.
- The storage temperature range is -40 to $+85$ °C.

2) HUMIDITY

- During normal operation humidity will not harm the power supply, provided the air is not aggressive. The heat normally produced in the power supply will keep it dry.
- **Condensation.**
Avoid condensation inside the power supply, break-down could be the result.
Condensation can occur during a period the power supply is switched off (or operating at no load) and the ambient temperature is increasing .
Always allow the power supply to dry before switching it on again.

3) GALVANIC INDUSTRY

- For using the power supplies in the galvanic industry it is strongly recommended to take precautions against an aggressive environment.
- An aggressive environment with acid, salt, etc. can harm the electronic components. Sometimes even the copper tracks on the pc-boards dissolve.
- To avoid problems the power supplies should be mounted in a relative clean room, or mounted in a cabinet receiving clean air with over pressure. Or a cabinet with a heat exchanger.

MAINTENANCE

1) GENERAL

- The SM-series power supplies normally need no maintenance or calibration. Only care must be taken that the cooling of the unit is not obstructed.

2) COOLING FANS

- The built up of dust on the impeller of the fans and the heat sink fins depends on the environment. Since the fans have over-capacity dust will not present a problem very quickly.
- The internal construction of the power supply is such that no dust will reach the sensitive control circuitry, only the heat sinks in a tunnel will be cooled by forced air, see fig. 4 - 13
- The thermal protection will shut down the output in case of overheating, so no damage will be done to the power supply.
- It is advisable to inspect the fans and the heat sinks regularly.

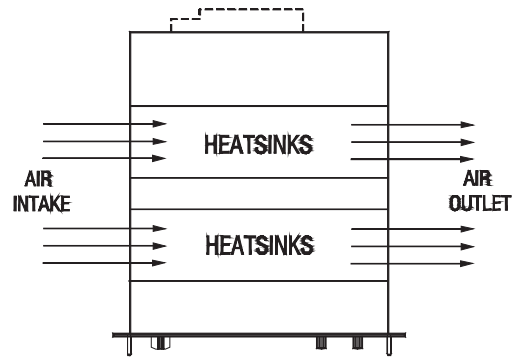

fig. 4 - 13

*the fans blow through an internal tunnel,
where the heatsinks are situated*

TROUBLE SHOOTING

1) GENERAL

- In case you need assistance for repairing the unit, please first fill in the Problem Report (also in this manual) and fax it to us.

2) NO OUTPUT (normal operation)

- Check the LED's 'Remote CV' and 'Remote CC' on the front panel, they should be off. Disable Keylock and press the REMOTE/LOCAL switch to turn both LED's off.
- The LED 'Output On' should be on. If this LED is off, disable Keylock and push the button 'OUTPUT ON/OFF'.
- Check the connections on the SENSE BLOCK (at rear panel), there should be a link between + and S+ and between - and S-. See fig. 3 - 16.
- Check if there is a link in the Interlock connector (if not, the RSD LED will be on).
- Set both the CV- and CC-limit potentiometer (at front panel) at maximum (fully clock wise).
- Switch on unit.
- Turn both the CV and CC potentiometers a few turns clock-wise. A voltage should be present on the output.

3) PROGRAMMING DOES NOT WORK OK

- Check the unit is in Remote mode (Remote CV and/or Remote CC LED should be on).
- **The unit works OK in manual control**, but in programming mode the output voltage / current has a large error. Probably the fuse in series with Ø (pin 1) of programming connector tripped, the fuse (F27_1 = 650 mA) is a self-resetting type. See fig. 4 - 14.
- To check the fuse (F27_1) measure the voltage between Ø and the minus output, during the fault condition. The voltage should only be a few mV, a high voltage means that an unwanted current is flowing through pin 1 of the prog. connector. Please check why current is flowing through pin 1, see also next paragraph 'programming offsets' and fig. 4 - 15.

4) PROGRAMMING OFFSETS

- **Unwanted offsets in the programming can be caused by earth loops.**
Fig. 4 - 15 shows a typical earthing problem. In case the load has a connection to earth and the programming source as well, problems could occur. Improper choice of the earthing point of the load can give a voltage drop of $\Delta V1$. Connecting the minus or zero to a separate earth connection can give a voltage drop of $\Delta V2$. Because the internal wires of the programming input are thin, the voltage drops $\Delta V1$ and $\Delta V2$ will be across the internal wiring as well. Resulting in a error voltage in series with the programming voltage.
- The best **solution** for this is using a floating programming source with the help of the optional internal **ISO AMP CARD** (ø-product) or a floating load.

5) STATUS OUTPUTS FAIL

- Check fuse F27_2 in series with Ø (pin 8 of CON E), see fig. 4 - 14. To check the fuse measure the voltage between Ø and the minus output, a high voltage means too much current flowing through the fuse. F27_2 = 650 mA, self resetting.

6) MASTER / SLAVE PARALLEL PROBLEMS

- Check the voltage drop of the wiring between the master and the slaves is < 10 mV.
- Check the wiring has a low inductance.

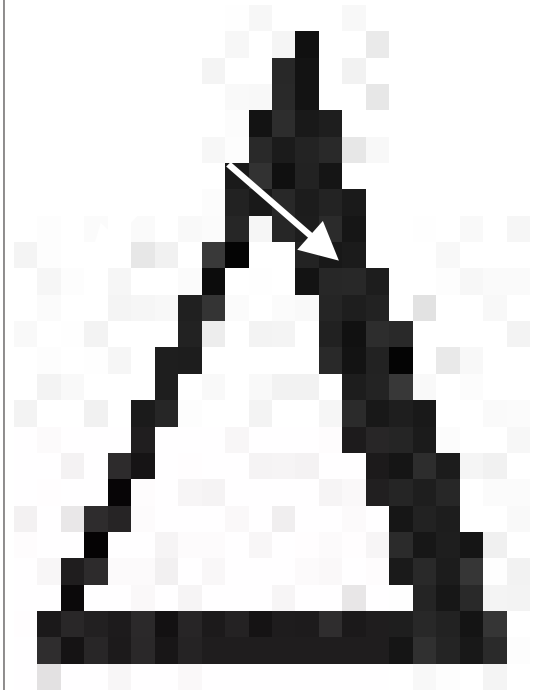

fig. 4 - 14
location of programming fuses on P598
P598 is situated directly behind the rear panel

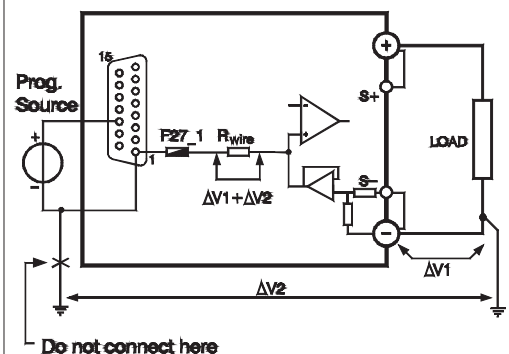

fig. 4 - 15
unwanted programming offsets

7) OUTPUT VOLTAGE IS HIGHER THAN SET VALUE

- Check connections on SENSE BLOCK (on rear panel), For normal operation there should be a link between + and S+ and between – and S–. See also fig. 4 - 16. When remote sensing is used, check the wires of the sensing.

8) OT LED on

- The temperature of the internal heat sink is too high, the output has been shut down to avoid overheating.
- Check if the cooling fans are running.
- Check if the air temperature of the air inlets (left) is below 50 °C

9) OT LED blinks

- The temperature of the internal heat sink is getting too high, a further increase will shut down the power supply.
- Check if the cooling fans are running properly.
- Check if the air temperature of the air inlets (left) is below 50 °C

10) ACF LED on

- Phase Loss, check input.
- The input voltage is too low or was intermittent because of a bad connection. Disconnect the mains, wait a few minutes and try again.
As soon as the ACF LED lights, the settings for Remote CV, Remote CC and Keylock will be saved. If the unit turns back on, it will have the same settings. For the setting of Output On/Off after turning the unit back on, the position of dipswitch 2 on SW1 is determining.
If the ACF situation lasts a few seconds, the output will shut down. The ACF problem has to be solved first, before the output can be turned on again.
- Internal error.

11) DCF LED on

- The output voltage is below the set voltage. This automatically happens when the unit is in CC-mode (CC LED is on). Also with an interrupted Interlock connector, the DCF LED will be on.
- Internal error

12) PSOL LED on

- The Power Sink is in overload or the temperature of the Power Sink is too high. See datasheet of the Power Sink option for further details.

13) NO LEDS on

- Check input.
- Do not try to repair, but send for repair.



fig. 4 - 16
for normal operation links should be connected
between S+ and + and between S- and -

CALIBRATION

1) GENERAL

- The power supplies are factory calibrated and normally need no further calibration.

2) METER CALIBRATION

- **DIGITAL METERS**
The full scale indication can be calibrated with R25_31 and R25_36 on P596 (fig. 4 - 17).

3) SPECIAL CALIBRATIONS

- The following calibrations must be done by qualified personnel only. Wrong calibration causes malfunction. These calibrations are only needed after special repairs. **Warning!** Damage caused by wrong calibration is not warranted.

- **CALIBRATING THE CURRENT MONITOR OFFSET.**

With R26_73 on P597 the offset of the CC monitor voltage can be calibrated. See fig. 4 - 18. The unit has to be unloaded, the output voltage has to be turned off using the OUTPUT ON/OFF button. Measure the offset voltage of the CC monitor on the prog. connector. Calibrate the offset on a negative value between -1 mV and zero mV.

Warning! wrong calibration can damage the unit.

- **CALIBRATING MAX. CURRENT RANGE or CALIBRATING CC MONITOR FULL SCALE.**

Short the output using a low resistive cable. The max. output current can be calibrated with R26_41. R26_41 is located on P597. See fig. 4 - 18.

Program CC input with exactly 5.00 V. Set output voltage to a low value, ensuring the power supply is in CC mode. Measure the output current with an accurate shunt. Calibrate the current with R26_41 exactly on the rated max. current.

Wrong calibration can damage

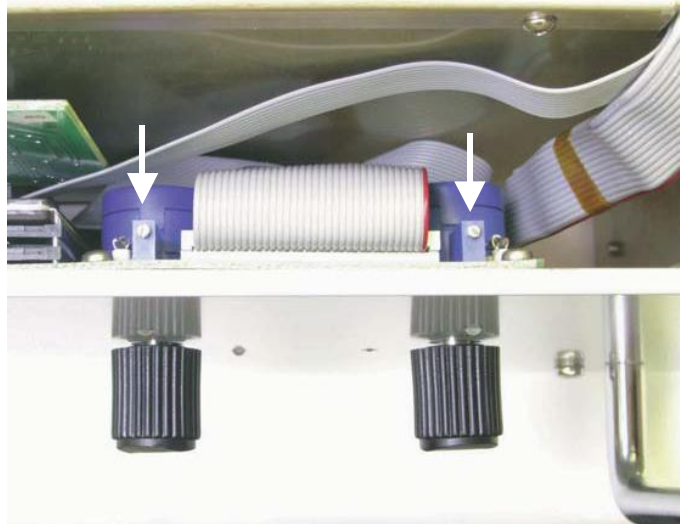

fig. 4 - 17 Meter calibration with 25-turn potentiometers on P596

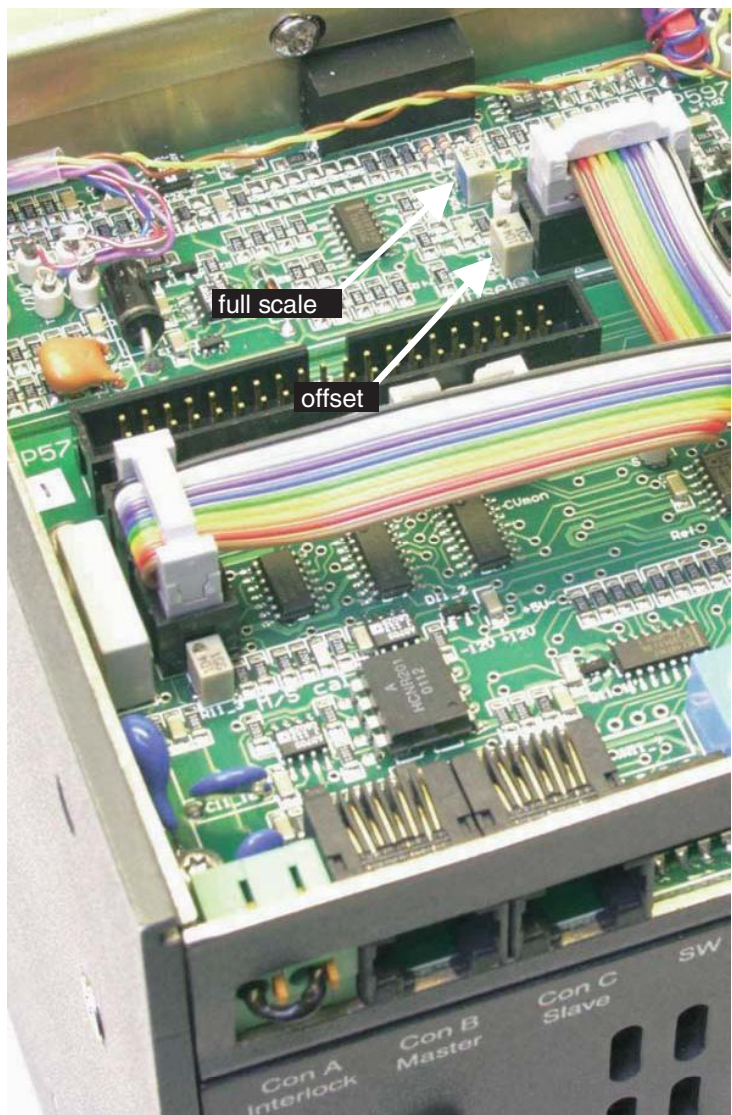

fig. 4 - 18 Calibrating max. current and offset on P597