

XLB-1000 Xenon Arc Lamp Driver

1000 Watts with Igniter

Features:

- **1000 watts output**
- **Low ripple current <0.5%**
- **Reliable short-pulse igniter**
- **Power Factor >.98**
- **Analog interface**
- **CE certified: IEC 60601-1**
- **Low cost, compact size**

The XLB-1000 is a high-performance current source designed to operate and control Xenon short-arc lamps. The design features a high frequency inverter section for low ripple and reduced arc wander in the lamp. To properly start the lamp the remote igniter delivers a fast rise time, short pulse for reliable ignition and reduced lamp electrode wear.

The XLB-1000 features a user-friendly analog interface that allows for easy programming and monitoring of output settings, as well as advanced safety features such as over-voltage, over-current, and over-temperature protection.

This versatile and reliable Xenon arc lamp driver is well suited for medical and industrial applications where a stable light source is essential.

Part Number Configurator

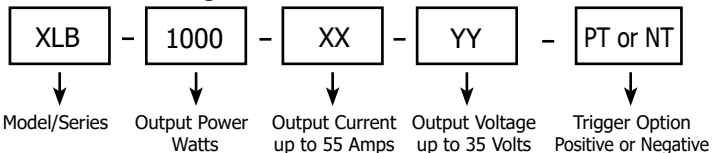

To complete the model description part number, please provide your required Max. Current for XX value and your required Max Voltage for the YY value and provide your required triggering polarity for either Positive or Negative.



Applications:

- **Digital Projection**
- **Film Projection**
- **Stage Lighting**
- **UV Sterilization**
- **Solar Simulation**
- **Medical Illumination**
- **Search Lights**

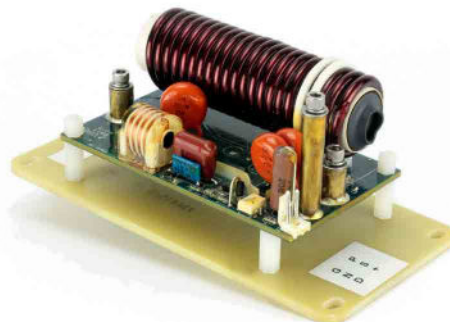

Remote Short-Pulse Igniter



Specifications

| Input | |
|--------------------|--|
| Voltage | 100 to 240VAC, $\pm 10\%$, 50/60 Hz |
| Power Factor | >.98 |
| Efficiency | >80% |
| Output | |
| Power | 1000 watts |
| Current (Max.) | 55 Amps |
| Voltage (Max.) | 35 Volts |
| Performance | |
| Line Regulation | <.2% of maximum output current |
| Current Regulation | <.5% of maximum output current |
| Current Ripple | <.5% of maximum output current |
| Power Limit | Limited to maximum power with fold back circuit |
| Certification | IEC 60601-1:2005 (Third Edition) + CORR. 1 (2006) + CORR. 2 (2007) +AM1 (2012) or IEC 60601-1 (2012 Reprint) |

| Ignition/Boost | |
|-------------------|---|
| Ignition Voltage | Up to $\sim 45\text{kV}$ ($\sim 1\mu\text{Sec}$, rise time) |
| Ignition Energy | 65mj. |
| Ignition Polarity | Positive or Negative (factory set) |
| Boost Voltage | Up to 275V |
| Boost Energy | 500 mj. |
| Environment | |
| Operating Temp. | 0 to 40°C |
| Storage Temp. | -25 to 85°C |
| Humidity | 0 to 95% RH non-condensing |
| Cooling | Forced Air |
| Dimensions | |
| Power Supply | L10.8" x W8.25" x H2.66" (271.8 x 209.5 x 67.6mm) |
| Igniter | L6.50" x W3.12" x H2.32" (165.1 x 79 x 59mm) |

Maximum output voltage is preset. Actual output voltage tracks the impedance of the lamp. Units can be paralleled for higher power applications.

Interface (15 pin D-Sub Female)

| Pin# | Pin Name | Functional Voltage Level | Description |
|--------|-----------------------|---|--|
| 1 | Lamp On/Off (input) | High = RUN = +5V to +15V Low = OFF = 0V | The Lamp On/Off function is the control function which turns the lamp on and off. When the lamp is turned on, a trigger and boost sequence will ignite the lamp and deliver current. |
| 3 | Interlock (Input) | Open = OFF, Connect to GND = RUN | The Interlock function can be connected to external interlock switches such as door or overtemp switches. |
| 4,9,15 | GND | | Interface Return |
| 5 | Vout Monitor (output) | 0-10V = 0-35V | The output voltage of the supply can be monitored by Vout Monitor. |
| 6 | Iout Monitor (output) | 0-10V = 0-Iout max. | The output current of the supply can be monitored by Iout Monitor. |
| 7 | Iprogram (input) | 0-10V = 20%-Iout max. | The power supply output current is set by applying a 0-10V signal to Iprogram. |
| 8 | Lamp Status | High = lamp off = 15V Low = lamp on = 0V | The status of the lamp can be monitored using this pin |
| 12 | -15V (output) | | Auxiliary 200mA. |
| 13,14 | +15V (output) | | Auxiliary 200mA. |

Outline Drawings

For more information on the proper installation and operation of the power supply and igniter please refer to the [XLB Application Notes](#)

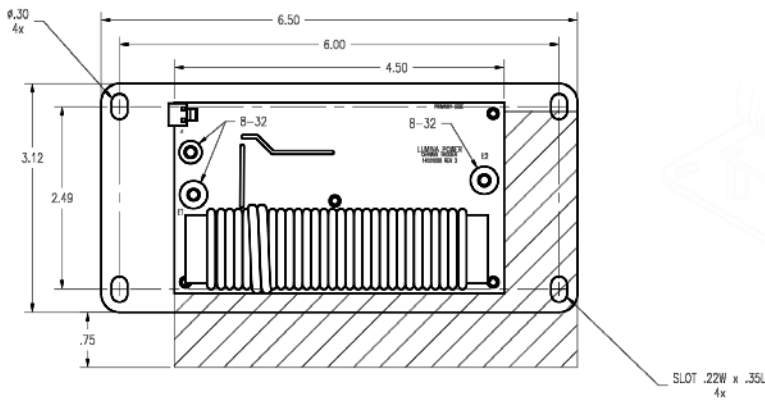
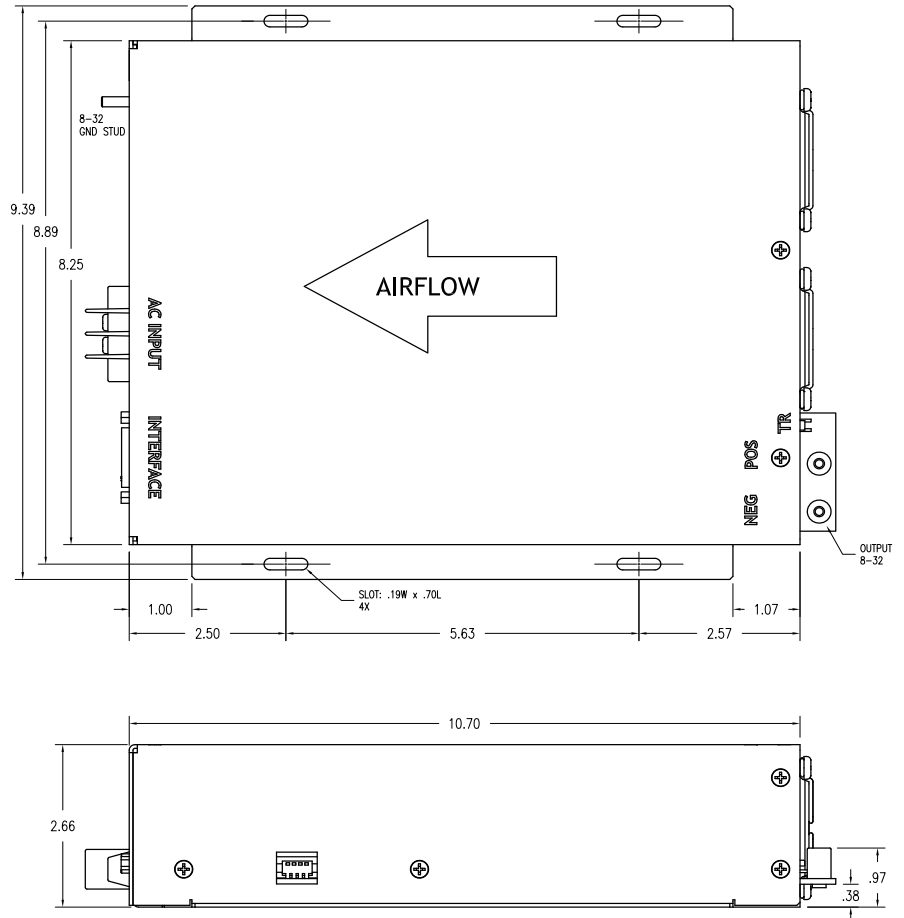

Igniter

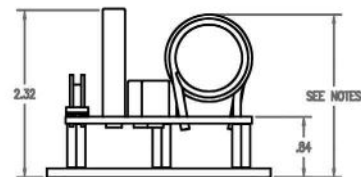

Your contact:



Schulz-Eberle
Professional Power Supplies

Schulz-Eberle GmbH
Dr.-Rudolf-Eberle-Straße 2
D-76534 Baden-Baden
Fon + 49.7223.9636.0

vertrieb@schulz-electronic.de
www.schulz-electronic.de