

HPW02401

240W(60°C) / 312W(40°C) DC Power Supply, TS35mm DIN-Rail



Specification:

- Up to 91,5% efficiency
- Natural convection
- Hold-up time >40ms
- N+1 parallel operation
- Remote Shutdown
- Precision current voltage curve
- Precise dynamic response on load change
- Electronic Inrush Limiter <7A
- Designed for long life under full stress
- Strong input filters
- High reliability, shock & vibration proof
- Over Voltage and continuous short circuit protection
- EMI/EMS EN61000-6-2,3, EN55032 class B
- EN61010-1, EN61010-2-201, EN62368-1

Models	Voltage	Voltage setting	Current
HPW02401.012	12Vdc	9 – 18Vdc	15A
HPW02401.024	24Vdc	18 – 30Vdc	10A
HPW02401.036	36Vdc	30 – 43Vdc	6,7A
HPW02401.048	48Vdc	43 – 53Vdc	5,0A
HPW02401.060	60Vdc	53 – 72Vdc	4,0A
HPW02401.072	72Vdc	68 – 86Vdc	3,3A



Your contact:



Schulz-Electronic
Professional Power Supplies

Schulz-Electronic GmbH
Dr.-Rudolf-Eberle-Straße 2
D-76534 Baden-Baden
Fon + 49.7223.9636.0
Fax + 49.7223.9636.90
vertrieb@schulz-electronic.de
www.schulz-electronic.de

Technical Concept

The Camtec HPW models are industrial high-performance power supplies „Made in Germany“. These power supplies are designed as a working horse for complex loads, and for battery charging.

For more than 25 years the Camtec Power Supplies manufactures high-end switch mode power supplies in Germany. A field breakdown of below 0,004% over a 10-year period under review approves our ambitious quality concept. Each manufactured Camtec product passes 100% tests for each detailed function and a full-load Burn-In test.

Although it is not required from the safety norms our production applies a routine safety test to each manufactured device, even if it is an extra low-voltage model. The components in the assembled device pass stress aging to achieve an even level and to prevent from delayed failures. Our internal product engineering guidelines provide a clear target: Camtec product reputation must say „mount and forget“. Quality is never a mere promise for our team.

The HPW power supplies provide low noise and ripple, and a precise setting at high load changes. With an efficiency up to 91,5% the devices are highly energy efficient.

Equipped with high-end capacitors of outstanding lifetime our power supplies guarantee a very long and reliable operation time. The circuit design of the HPW series allows cope playing with complex loads. The internal protection circuits protect the power supply and the connected system, even in exceptional situations. The HPW series is protected from high transients by strong filters with high energy efficiency. All inputs and outputs are electrically isolated. The design specifications call for the highest standards of safety and interference suppression.

Design Conception

The HPW power supply series realizes high power in a space-saving housing. Latest generation electrical devices relate to the high reliability of all CAMTEC products. The CAMTEC philosophy is, to employ 125°C low ESR ultra long-life capacitors where expedient to achieve a superior lifetime of the product. The HPW power supply is made for high reliable and demanding industrial applications like galvanic systems, professional DC-drives, UPS-System, and high dynamic load.

Galvanic Isolation

The power supply is galvanic isolated between the input and the output. All features are connected to the DC power outputs.

Thermal shutdown

The HPW units are featured with a thermal overload shut down and auto recovery behaviour.

Over Voltage Protection

Ticker mode and auto recovery

Short Circuit Protection

A continuous short circuit does not cause damage to the power supply. The HPW units deliver constant current and zero output voltage. They recover automatically after the short circuit is released.

Open Circuit Protection

The HPW series is continuously open circuit protected. The device delivers a stable output voltage and no current. If a load is immediately connected to the device, the power supply stabilizes within 1ms. It does not overshoot the output voltage.

Power Up Ramp

The devices have a soft start ramp when powering up. The device does not either overshoot the voltage nor does the output flutter independent if a load is connected or not.

Remote Shutdown

The unit is equipped with a remote shutdown function that allows switching the power supply on and off from external.

DC-ok Power Good Relay

The PG Relay connection indicates over temperature, low DC-voltage at the output, low AC supply voltage at the input, and the shutdown mode.

Current Voltage Chart, CV & CC mode

The HPW series provides a perfect current voltage chart. It has no fold back or other abnormalities. The output voltage can drop down to zero volts when the power supply is overloaded. The unit delivers a stable and constant current to the outputs.

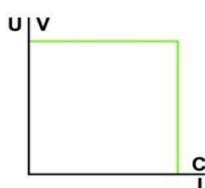



Technical Table

AC Input Range	85-264Vac					
AC Input Frequency	47-63Hz					
DC Input Range	90-350Vdc					
AC Input Rated	115Vac<3.3A 230Vac<1.6A					
DC Input Rated	90Vdc<4.2A 350Vdc<1.1A					
DC Voltage Rated	12Vdc	24Vdc	36Vdc	48Vdc	60Vdc	72Vdc
DC Voltage Setting Range	9-18Vdc	18-30Vdc	30-43Vdc	43-53Vdc	53-72Vdc	68-86Vdc
DC Current Rated +40°C	19A	13A	8.7A	6.5A	5.2A	4.3A
DC Current Rated +60°C	15A	10A	6.7A	5.0A	4.0A	3.3A
DC Current Rated +70°C	11.3A	7.5A	5.0A	3.8A	3.0A	2.5A
Power Boost 60s +60°C	18A	12A	8.0A	6.0A	4.8A	4.0A
Ripple Noise 230Vac 20MHz	30mVpp	30mVpp	60mVpp	50mVpp	50mVpp	60mVpp
Over Voltage Protection	22Vdc	35Vdc	51Vdc	59Vdc	84Vdc	100Vdc
Over Current Protection	20A	13.5A	9.0A	6.8A	5.4A	4.5A
Load regulation 0-100%	± 0.5%	± 0.2%	± 0.2%	± 0.1%	± 0.1%	± 0.1%
Power Rated	312W @ +40°C / 240W @ +60°C, 85-264Vac					
Start-up Delay	Typ. 130ms @ 230Vac, 280ms @ 115Vac					
Softstart	Typ. 10ms					
Response Load Change	<1ms 10-100%, 100-10%					
Base Load	None					
Efficiency 230Vac	91.5% typical					
Short Circuit Protection	Continuous					
Idling-proof	Yes					
Temperature Control	Yes, thermal shutdown with auto recovery (+70°C, metering distance 50mm)					
Hold Up Time	> 40ms 230Vac					
Inrush Current	< 7A (100-230Vac) active electronic limiter					
MCB (Circuit Breaker)	10A curve B					
Cooling	Natural convection					
Ambient Operating Temp.	- 25°C...+70°C, derating 2,5%/°C >60°C					
Ambient Storage Temp.	- 40°C...+85°C					
Environment	Humidity 95% non-condensing @ 25°C, climate class. 3k3, pollution degree 2					
ROHS	2011/65/EU, (EU)2015/863					
REACH	EG No. 1907/2006					
EMI	EN55032 class B, EN61000-6-3, EN61000-3-2					
EMS	EN61000-6-2					
Safety	EN61010-1, EN61010-2-201, EN62368-1, EN60950-1, EN60204-1					
Protection Class I	PE connection required					
Creepage Distance	> 8mm					
Input to Output Isolation	3000Vac					
Input to Case Isolation	2500Vac					
Output to Case Isolation	500Vdc, ≥60Vdc 1500Vdc					
MTBF (IEC61709)	500000h (Meantime Between Failures: statistic time between failures after repairs)					
MTTF (IEC61709)	159738h (Meantime To Failure: statistic time to ever fails)					
Dimensions (HxWxD)	130x75x114.8mm					
Weight	1,2kg / 2,7lbs					
Input & Output Terminals	Spring-type terminal solid max. 0,18...6mm ² 26...10AWG according with IEC/EN60664-1, IEC/EN61984 Use copper conductors only. Wire stripping length 7mm. Tightening torque per terminal block is 0.5 - 0.6 Nm / 4.5 - 5.3 lbf-in					

Manual und Technical Details

Temperature Derating

The maximum ambient temperature during operation is + 70°C. If the over temperature protection is activated, the power supply is switched off.

The measuring point is 50mm outside the power supply. The power supply unit starts automatically when it has cooled down.

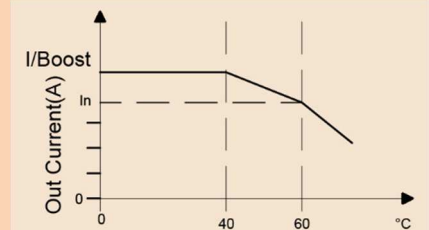

C/V Current Voltage Behaviour

The HPV series provides a perfect current voltage chart. It has no fold back or other abnormalities. The output voltage can drop down to zero volts when the power supply is overloaded. The unit delivers a stable and constant current to the outputs.

When the output voltage is set to the maximum demanded value and the current limit circuit acts, the output voltage drops linear down to zero and the unit delivers constant current.

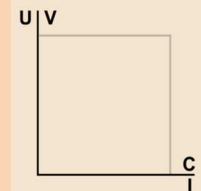

Parallel Operation & N+1 Decoupling

To increase the overall power of the power supply, two or more devices of the same model with the same output voltage may be operated in parallel. We recommend using a busbar for the DC power connector. Make sure that the cable lengths and cable cross-sections of all power supplies to the busbar or to the star point are identical. Allow proper connection for low contact resistance.

The HPW models have no internal O-ring diode, to operate the devices N+1 redundant. Such, we recommend using our RED00202 DIN-rail redundant decoupling modules.

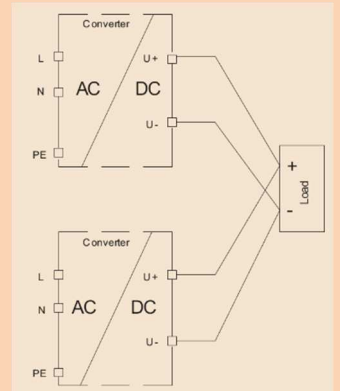

Redundant Parallel Operation & N+1 Decoupling

If one of the devices does not work properly, the backup device will provide necessary power to the equipment.

Make sure that the cable lengths and cable cross-sections of all power supplies to the load or to the star point are identical. Allow proper connection for low contact resistance.

The HPW models have no internal O-ring diode, to operate the devices N+1 redundant. Such, we recommend using our RED00202 DIN-rail redundant decoupling modules.

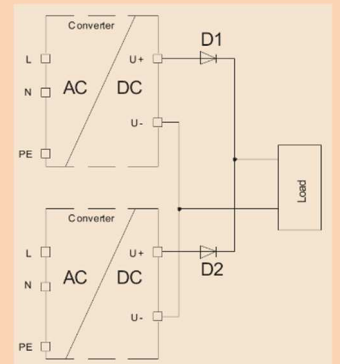

Technical Data Table – Power OK Connection & Voltage Setting

Feature	Technology	Details and Connections	Section	Isolation
Potentiometer Voltage	25 turns	High precision	U adj	3000Vac to input & 500Vdc to output
Power Good Relay	“b” contact	AWG24 – AWG14 / 0,25 – 2,5mm ²	DC-ok	3000Vac to input & 500Vdc to output

DC Voltage setting range

Rated DC Voltage	12Vdc	24Vdc	36Vdc	48Vdc	60Vdc	72Vdc
DC Voltage Setting Range	9-18Vdc	18-30Vdc	30-43Vdc	43-53Vdc	53-72Vdc	68-86Vdc
Rated DC Current +40°C	19A	13A	8.7A	6.5A	5.2A	4.3A
Rated DC Current +60°C	15A	10A	6.7A	5.0A	4.0A	3.3A
Power Boost 60s +60°C	18A	12A	8.0A	6.0A	4.8A	4.0A
Overvoltage Protection	22Vdc	35Vdc	51Vdc	59Vdc	84Vdc	100Vdc

The DC voltage can be adjusted with a precision 25 turns potentiometer with low temperature fading. The factory setting is to the rated voltage from the table above.

C/V Current Voltage Behaviour

The HPW operates in accordance with the V/C-characteristic line. When a DC short circuit or an overload occurs to the HPW02401, it is not shot down and it limits to the current boost. The DC-voltage is lowered until the error is rectified. The V/C-line and the power boost applies operation of critical loads, like capacitive loads DC/DC-converters, capacitive loads, drives and batteries, trustworthy.

Voltage	Current +40°C	Current +60°C	Voltage	Current +40°C	Current +60°C
9Vdc	19,0A	15,0A	32Vdc	8,7A	7,5A
12Vdc	19,0A	15,0A	34Vdc	8,7A	7,1A
15Vdc	17,1A	13,5A	36Vdc	8,7A	6,7A
18Vdc	15,6A	12,0A	40Vdc	7,8A	6,0A
20Vdc	13,0A	11,3A	46Vdc	6,8A	5,2A
22Vdc	13,0A	10,7A	53Vdc	5,9A	4,5A
24Vdc	13,0A	10,0A	60Vdc	5,2A	4,0A
26Vdc	12,0A	9,2A	65Vdc	4,8A	3,7A
28Vdc	11,2A	8,6A	72Vdc	4,3A	3,3A
30Vdc	10,4A	8,0A	86Vdc	3,6A	2,8A

LED Signal Indication

Indicators	DC-ok LED green	Overload LED red	Shutdown LED yellow	DC-ok Relay
Normal operation	On	Off	Off	Closed
Power boost	On	Off	Off	Closed
Overload (0.9xVout)	Off	On	Off	Open
Shutdown with open contact	On	Off	Off	Closed
Shutdown with 10...30Vdc	Off	Off	On	Open
Shutdown with <500mVdc	Off	Pulse	Pulse	Open
Temperature shutdown	Off	Off	Off	Open
Input voltage low or fail	Off	Off	Off	Open

External Shutdown (SD)

The power supply is set to the Shutdown mode when a voltage of 10 to 30V (max. 20mA) is applied to the control input. The yellow LED lights and 0V is distributed to the DC-output.

Alternatively, the control input can be shorted either via a relay contact, a switch contact or an NPN transistor with open collector (voltage drop <0,5V). The HPW „tickers“ with a period of 850ms, the yellow LED flashes and approx. 0,2xVrated is distributed to the DC-output. If the shutdown repeats the power supply starts with a typical delay of 850ms.

Using the soft start, the current and the voltage rises within 10ms continuously to the default set values. Note that the input is not floating. The common ground is internally connected to the DC-minus output.

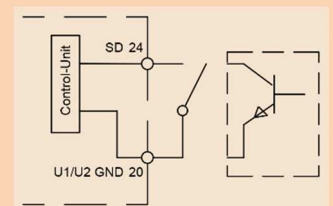

DC-OK Relay

The DC ok relay indicates if the output voltage is low and if the AC voltage is low. The contact is galvanic insulated to the AC input and the DC output connections. The isolation to the AC input is 3000Vac with a forced isolation and covers the overall adjustment range of the HPW models. If the DC voltage is ok the relay is closed, if the power supply unit is in false operation the relay is open. Considering the lower and the upper margin of the AC voltage detection it is to say that the HPW series starts at 80Vac. The unit starts with 75Vdc when a DC voltage applies to the input. DC-Fail hysteresis: drop-out 90% V_{out} / pull-in 100% V_{out} . Contact Rating 30Vdc/1A, 60Vdc/0.3A, 30Vac/0.5A

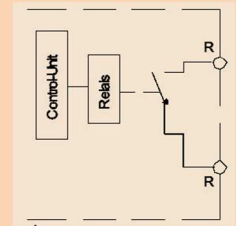

DC OK Indication

Power Supply Status	Normal	Over Temperature	AC Low [V]	DC Low [V]
Relay Operation status	Closed	Open	Open	Open

Inrush Current Limiter

The unit is featured with an electronic inrush current limiter 4,9Arms / 7Apeak. The built-in circuit is a very precise limiter and no simple NTC thermistor solution. The circuit works with an accuracy of $\pm 10\%$. The accuracy is independent from the ambient temperature and from the number of switch-on sequences. The quickest recommended MCB is B-type 10A. The smallest power relay or a contactor in front of the HPW must cope 7A peak current. The inrush duration is 80ms and the overall power up time of the unit is 130ms. See the below drawings for technical information.

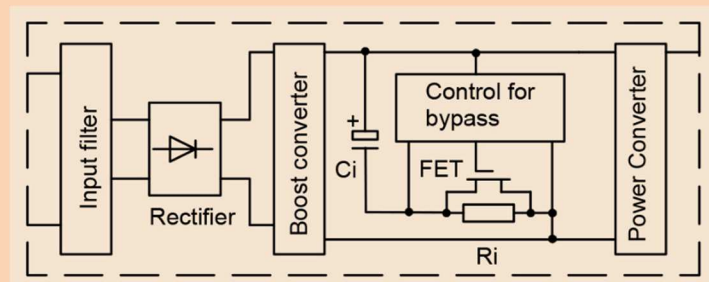
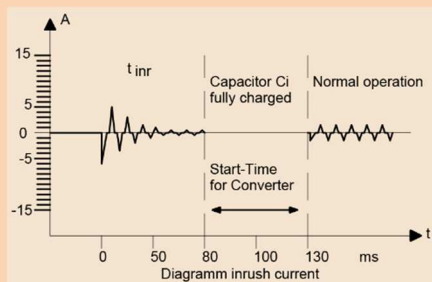

Coating Option

We offer the HPW-series with optional coating. It is to be used in e.g. dusty, dirty, high humidity, or in awaiting quick temperature changes. Short circuit and corrosion at print board lines and at solder points can be prevented. The coat itself is a transparent acrylic resin. Peters SL 1306 N-FLZ (transparent) IEC60216-1 2001, IPC-CC-830B, UL listed as permanent coating File No.: E80315 , UL94V-0

Electrical Safety (Factory-Test / Field-Test Owner)

	T	A	B	C ²⁾	D
Type Test	60s	2500Vac	3000Vac	500Vdc	500Vdc
Factory Test	5s	2000Vac	1500Vac ¹⁾	500Vdc	500Vdc
Field Test	2s	2000Vac	1500Vac ¹⁾	500Vdc	500Vdc
Cut-off current setting	>15mA	>15mA	>1mA	>1mA	>1mA

¹⁾ $\geq 60Vdc = 2000Vac$
²⁾ $\geq 60Vdc = 1500Vdc$

Type and factory test are the manufacturer. While repeating damage can happen to the power supply unit. For the field test (owner) follow the below instruction:

- Use suitable test equipment, raising the voltage slowly
- Short circuit L1 and N, and all the DC output terminals.
- Use only test voltages of 50/60Hz. The outputs are unearthed and therefore they have no resistance to GND/PE.
- If the residual voltage is $\geq 60Vdc$, observe the safety standards. Use only specially insulated screwdriver to trim the U_a/I_a .

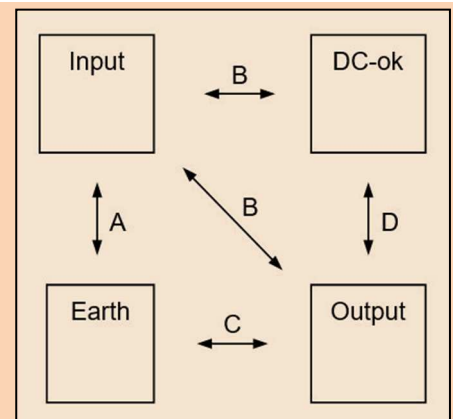

Mechanics

Mechanics & Installation Instruction of the HPW

Stable metal/aluminium housing IP20. To allow adequate convection, a free air space of 50mm (top/bottom) and 10mm (sidewalls) is required; and for active devices 15mm space from the sidewalls. One can use the DIN-Rail installation (equipped standard) with our patented 35mm DIN-Rail bracket according to EN60715. It is easy to mount/dismount while snapping it onto the 35mm DIN-Rail - no tools necessary. **It is not allowed to install the HPW in other mounting direction then below drawings.**

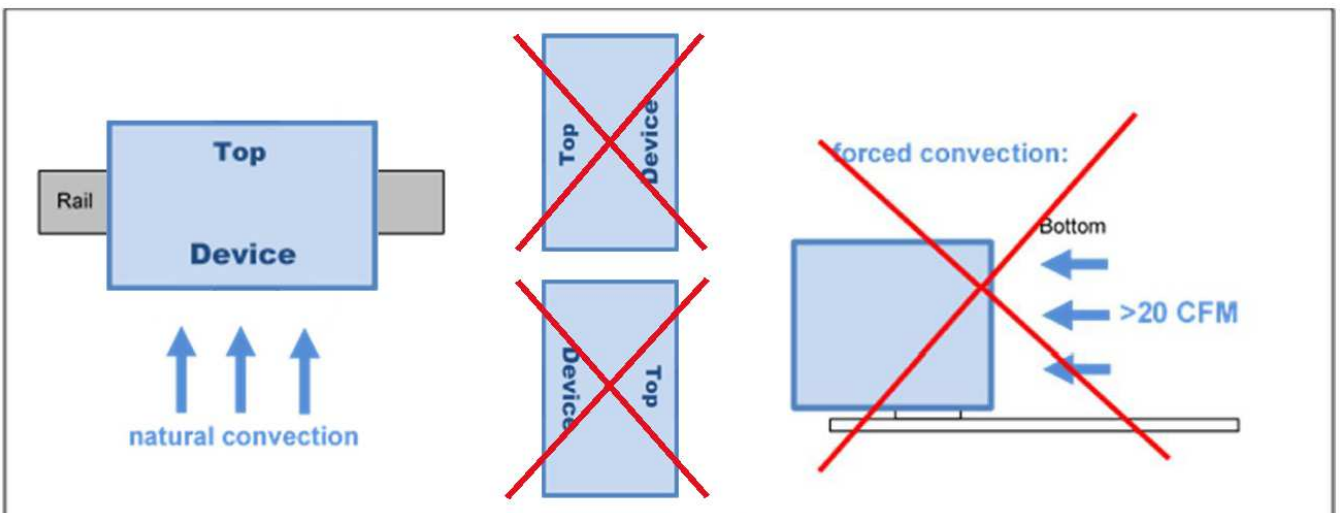
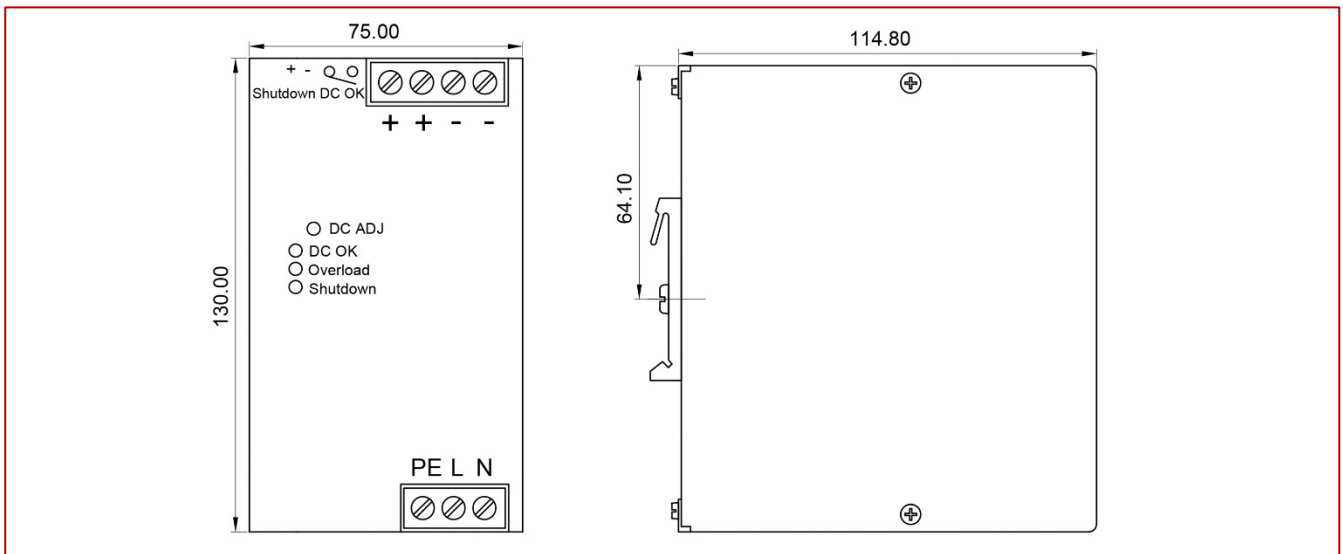

Mounting Instruction: recommended air flow space below and above is 50mm (2 Inch)

Connections

Clamping Yoke Connector Specifications

	Input / Output connections	Optional AUX Connection Plugs Power OK / Shut Down
Tightening torque min. – max.	0,5 – 0,6Nm (blade 1,0x5,5 DIN5264)	0,4 – 0,5Nm (blade 0,6x3,5 PH1 PZ1)
Touch-safe protection acc. to DIN VDE 0470	IP20 plugged/ IP10 unplugged	Not applicable
Clamping range, min. – max.	0,18 – 6mm ² / AWG26 – AWG10	0,2 – 4,0mm ² / AWG26 – AWG12
Solid, H05(07) V-U min. – max.	0,18 – 6mm ²	0,2 – 4,0mm ²
Stranded, H05(07) V-U min. – max.	0,22 – 4 mm ²	Not applicable
Flexible, H05(07) V-U min. – max.	Not applicable	0,2 – 4,0mm ²
w. plastic collar ferrule, DIN 46228 pt 4 min. – max.	0,5 – 2,5mm ²	0,2 – 2,5mm ²
w. wire end ferrule, DIN 46228 pt 1, min. – max.	0,5 – 4mm ²	0,2 – 4,0mm ²
Plug gauge in accordance with EN 60999 a x b; ø	3,6 x 3,1mm; 2,7mm	2,8 x 2,4mm; 2,5mm
Pitch (P)	9,52mm	5,08mm

Wire Stripping Length (fine wired)

Nominal Cross Section	Wire End Ferrule	Stripping Length	Wire End Ferrule	Stripping Length
0,25mm ²	H0,25/5	5mm	H0,25/10 HBL	8mm
0,5mm ²	H0,5/6	6mm	H0,5/12 OR	8mm
1,0mm ²	H1,0/6	6mm	H1,0/12 GE	8mm
2,5mm ²	H2,5/12	12mm	H2,5/19D BL	14mm
4,0mm ²	H4,0/12	12mm	H4,0/20 GDR	14mm
6,0mm ²	H6,0/20	12mm	H6,0/20 SW	14mm
10,0mm ²	H10,0/12	12mm	H10,0/22 EB	15mm

The length of ferrules is to be chosen depending on the rated voltage. The outside diameter of the plastic collar should not be larger than the pitch (P)

Ordering Information

Ordering Codes

Product Code	Information	Article Number
HPW002401.012(R2)	12V	3041078004CA
HPW002401.024(R2)	24V	3041078007CA
HPW002401.036(R2)	36V	3041078010CA
HPW002401.048(R2)	48V	3041078008CA
HPW002401.060(R2)	60V	3041078009CA
HPW002401.072(R2)	72V	3041078002CA
Optional AUX Connection Plugs	Optional, 2poles Clamping Yoke Connector 180° cabling (10pcs per pack)	3520037



Safety regulations: Please read these instructions completely before using the equipment. Keep these instructions on to hand. The device may only be operated by trained specialist staff.

Installation:

- 1) The device is designed for devices and systems that meet the standard requirements for hazardous voltages, power, and fire prevention.
- 2.) Installation and service only by trained specialists. The AC power must be switched off. The work is to be labelled; accidental reconnection of the system must be prevented.
- 3.) Opening the device, its modification, loosening bolts, or operation outside the specified herein specification or in an unsuitable environment, has the immediate loss of warranty to follow. We disclaim any responsibility for any resulting damage to persons or things.
- 4.) Note: The device must not be operated without an upstream circuit breaker (CB). We recommend the use of B-Type 10A. It is prohibited to use the unit without PE. It may be necessary upstream device has a power switch.

Warning:

Non-compliance these warnings can result in fire and serious injury or death.

1. Never operate device without PE connection.
2. Before connecting the device to the AC network, make wires free of voltage and ensure that it cannot accidentally switch on.
3. Allow neat and professional cabling.
4. Never open nor try to repair the unit. Inside are dangerous voltages that can cause electrical shock hazard.
5. Avoid metal pieces or other conductive material to fall into the item
6. Do not operate the device in damp or wet conditions
7. Do not operate the unit under EX-conditions



All parameters base on 15 minutes run-in @ full load / 25°C / 230Vac 50/60Hz, as otherwise stated.